

OPERATOR'S MANUAL

INSTALLATION • OPERATION • MAINTENANCE
SAFETY PRECAUTIONS • REPAIR PARTS

WESTERN MULE

FOLD - **A** - WAY
CRANE

Model: **P7-VAN**

*700 Lb. MAXIMUM
LIFTING CAPACITY*

SERIAL NO. _____

▲ CAUTION

THIS EQUIPMENT CAN BE POTENTIALLY DANGEROUS. THIS MANUAL MUST BE STORED WITH THE EQUIPMENT. ALL INFORMATION AND INSTRUCTIONS CONTAINED IN THIS MANUAL MUST BE READ IN FULL BY ALL OPERATORS OF THIS SYSTEM, AS WELL AS PERSONNEL SUPERVISING THE OPERATION OF THIS EQUIPMENT. FAILURE TO DO SO MAY RESULT IN UNSAFE CONDITIONS THAT COULD RESULT IN INJURY OR DEATH. IF ANY INSTRUCTIONS ARE UNCLEAR, CONTACT THE MANUFACTURER FOR CLARIFICATION PRIOR TO USE OF THE CRANE.

Western Mule Cranes
1510 Merced Street
Fresno, CA 93706 USA

Ph: 559-266-6977 Fax: 559-266-7437
Email: cranes@westernmule.com
www.westernmule.com

READ THIS FIRST

THIS MANUAL CONTAINS VERY IMPORTANT INFORMATION
ABOUT THE INSTALLATION AND OPERATION OF YOUR WESTERN MULE CRANE. FOR YOUR OWN SAFETY AND THAT OF FELLOW WORKERS, READ THIS MANUAL COMPLETELY PRIOR TO ATTEMPTING INSTALLATION OR OPERATION OF THE WESTERN MULE CRANE.

The information in this manual is intended to help insure that your Western Mule Crane is installed properly and operated safely.

Although every effort has been made to make this manual complete and understandable, it is not a definitive guide to every possible situation or circumstance.

The safe operation of this product is directly dependent on the operator's skill, knowledge and judgment.

To avoid hazardous situations, every operator must be knowledgeable with appropriate safety guidelines, codes and regulations that are applicable. Remember that a uniformed or careless operator can make the operation of any equipment dangerous.

Ultimately the owner/operator must make the final decision as to how this product will be used and whether that intended use is safe. Keep in mind that every piece of equipment has its limitations.

After reading this manual in its entirety, should you have any questions regarding the installation or the safe use/operation of a Western Mule Crane, contact your Dealer or Western Mule Cranes Customer Service Department for assistance.

Replacement manuals are available from your Dealer or:

Western Mule Cranes

1510 Merced Street

Fresno, CA 93706 USA

Ph: 559-266-6977 Fax: 559-266-7437

E-Mail: cranes@westernmule.com

www.westernmule.com

TABLE OF CONTENTS

READ THIS FIRST	Page 2
A WORD TO OWNER, OPERATOR, AND SERVICE PERSONNEL	Page 4
INTRODUCTION	Page 5
ILLUSTRATION	Page 7
SAFETY – SAFE OPERATION	
General Operation	Page 8
Setting up at the job site	Page 10
Making the lift	Page 10
Load Chart	Page 12
Leaving the job site	Page 13
Rotation Brake	Page 13
Emergency/Auxiliary Hand Crank	Page 13
Further Suggestions	Page 14
INSTALLATION	
Preparing for Installation	Page 16
Installation	Page 16
Bolt Torque Specifications	Page 18
Wiring Diagram	Page 18
INSPECTION	
Daily Inspection	Page 19
Lifting Cable & Hook Inspection	Page 21
MAINTENANCE	
CABLE Replacement	Page 22
PARTS	
Replacement Parts	Page 23
Winch Parts	Page 24
GENERAL PRODUCT INFORMATION	Page 25
REPLACEMENT PART ORDERING INFORMATION	Page 25
PRODUCT REGISTRATION	Page 25
WARRANTY	Page 27

A WORD TO THE OWNER/EMPLOYER, OPERATOR AND SERVICE PERSONNEL ABOUT SAFETY

This manual was written with the safety of the operator and others who work around this equipment as our goal.

IT IS THE OWNER/EMPLOYERS' RESPONSIBILITY to know the specific requirements, governmental regulations, precautions and work hazards which may exist. You should make these known to all personnel who are working with the equipment or in the work area, so all necessary precautions and required safety procedures are followed. Failure to heed these instructions can result in serious personal injury and or death.

IT IS THE OWNER/EMPLOYERS' RESPONSIBILITY to instruct and insure that all operators understand the safe operation of the Western Mule Crane and to provide the operator with properly maintained equipment.

Anyone who will operate, service or work around this crane should first read and fully understand this manual. Death or serious personal injury can result from improper use or maintenance of this Western Mule Crane.

IT IS YOUR RESPONSIBILITY to operate and maintain your Western Mule Crane with skill, good judgment, and caution. Following recognized safety procedures will help prevent accidents. Modification to any part of the Western Mule Crane can create a safety hazard and therefore shall not be made without the manufacturer's prior approval. Use only factory-approved parts to repair or maintain the Western Mule Crane.

Keep children, visitors, and unauthorized personnel away from the work area.

Be capable, careful, and concerned!

Make safety your everyday business!

LOAD CHART

Boom Position	A	B	C
3	700	600	500
2	700	575	450
1	700	550	400

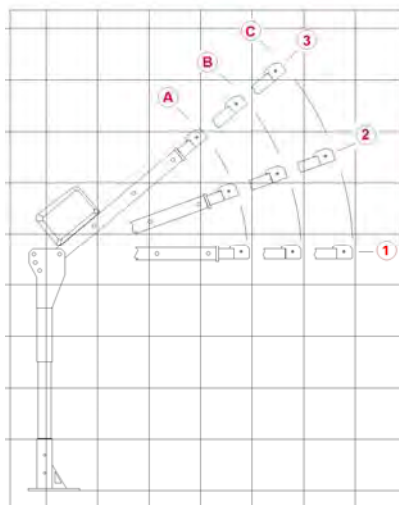

INTRODUCTION

WESTERN MULE CRANES have been engineered to provide safe, trouble-free, dependable service for many years when these products are properly used and maintained.

To assist you in obtaining the best service from your crane and to avoid untimely failure of the unit and/or the vehicle on which it is mounted, the following operating and service instructions are herein published. It is specifically recommended that all operating and service personnel consider this manual as mandatory material for reading and study before operating or servicing of Western Mule Products. It is highly recommended that crane owner, equipment managers, and supervisors also read this manual.

Remember that the crane adds weight to the vehicle and may change the driving and riding characteristics of the vehicle on which it is mounted. The payload of the vehicle is also reduced by the amount that the crane weighs, (CAUTION! be sure with the additional weight of the crane, you do not exceed the maximum gross vehicle weight rating for the vehicle) and as the vehicle is loaded, care should be exercised not to overload the vehicle. Exercising care in distributing the payload on the vehicle will greatly improve the driving and riding characteristics of the vehicle.

Western Mule Cranes are powered directly by your 12-volt truck electrical system. The power cable is included with each crane. The performance of your new crane depends on the truck electrical system. The minimum recommended alternator and battery size that will give the longest life with the most useful duty cycle is a 80 amp. alternator with a 500 cold cranking rated battery.

In the event that Western Mule Cranes receives a warranty claim, it is our policy to respond to the claim as promptly as possible. If material or workmanship is involved immediate, corrective action is taken. It is therefore, understandable that Western Mule Cranes will not assume responsibility, or liability, when one of our products has obviously been abused, misused, overloaded, or otherwise damaged by inexperienced persons trying to operate the equipment without ever reading this manual. The Western Mule is designed and built to be safe and efficient. Western Mule Cranes will not assume responsibility or liability for any unit which has been modified, changed, or has unauthorized, unapproved components installed.

Continued next page...

INTRODUCTION

...Continued from previous page

Western Mule Cranes maintains a strong Distributor network and knowledgeable Customer Service Department. In most cases, equipment related problems could be solved through a telephone conversation with a service representative. If through no fault of Western Mule Cranes it becomes necessary to send an experienced factory technician on a field call, all charges incurred will be billed to the customer.

The Occupational Health and Safety Act of 1970 state that it is the employer's responsibility to provide a work place free of hazard. To accomplish this, all equipment should be installed, operated, and maintained in compliance with applicable trade, industrial, federal, state, and local regulations. It is the responsibility of the equipment owner to obtain copies of these regulations and, from these, to determine the suitability of the equipment to any particular use.

This owner's manual and all labels attached to the product are intended to serve as guidelines for hazard free installation, operation, and maintenance. They are not however, intended to prepare the user for every possible situation.

It is the responsibility of the equipment owner to keep this owner's manual, all labels legible, and available with the crane at all times. If they should become lost or illegible, immediately order replacements from the factory.

The material herein does not imply to cover all maintenance instructions, operating instructions, or variations to every possible situation. If additional information is required, please refer to Western Mule Cranes the following telephone number (559) 266-6977. The information contained in this manual was in effect at the time of printing. Western Mule Cranes reserves the right to update this manual at any time without notice.

P7-VAN ILLUSTRATION

Refer to this illustration until you become familiar with the operation of the crane.



Note: Photo shows model P10-DC, which shares the same parts as model P7-VAN.

GENERAL OPERATION

⚠ CAUTION

THE FOLLOWING CONTAINS SOME GENERAL PRECAUTIONS THAT MUST BE CAREFULLY FOLLOWED WHEN INSTALLING, OPERATING, OR MAINTAINING A WESTERN MULE CRANE.

This Crane **must be** operated by persons, both qualified and trained, in its safe use, only in accordance with the manufacturer's instructions and applicable governmental safety requirements.

READ AND OBEY ALL information contained in this operator's manual and on all placards and decals attached to the Western Mule Crane. A careless or untrained operator can make the use of any equipment dangerous and may cause property damage, serious personal injury, and/or death.

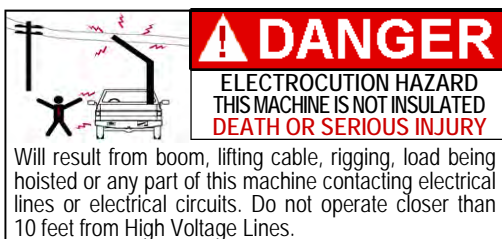

KEEP ALL bystanders clear of the operation area to prevent obstruction of the operation and/or to avoid serious personal injury and/or death.

KEEP hands away from sheaves, lifting cable, pinch points and, moving parts of the crane, which may cause serious personal injury and/or death.

ALWAYS be certain the rigging that you intend to use is capable of withstanding the load. Never wrap the lifting cable around load. This will cause damage to the lifting cable.

DO NOT divert your attention from the Western Mule Crane while an operation is being performed.

CONSTANTLY check for signs of damage or poor operation. Make sure that the load remains unobstructed and securely attached.

AVOID lifting loads over persons or the operator himself. To do so may cause serious personal injury and/or death.

GENERAL OPERATION

NEVER operate the crane in the stored position. Cable failure will result!

SHOULD avoid continuous use of the crane to prevent overheating of the electric motor.

DO NOT operate the Western Mule Crane if signs of damage or poor operation are noticed. To do so may result in property damage, serious personal injury, and/or death. Place a “**DO NOT USE - CRANE OUT OF ORDER**” sign on the Western Mule Crane and in the vehicle. Do not use until the Western Mule Crane is repaired by a qualified maintenance person who has seen to the complete correction of the problem and inspection of the crane removes the signs.

KNOW the weight of the load you are lifting to avoid overloading the Western Mule Crane.

DO NOT overload the Western Mule Crane or exceed the load rating of the weakest component in the system (I.E. the lifting cable, sling, lifting attachment, etc.). Overloading may result in damage and/or failure of the equipment, which may lead to serious personal injury and/or death.

DO NOT use two cranes to move a load that is greater than the load rating of a single crane. A shift in the load may place all the weight on one crane, which may overload the equipment and/or cause it to fail.

MAKE SURE That a minimum of five (5) wraps of lifting cable are always maintained on the winch drum at all times.

ALWAYS keep your hands away from the lifting cable while tensioned and from moving parts while in use.

NEVER handle the lifting cable/rigging while someone else is at the controls.

DO NOT shock load/bounce or swing the load. Such violent motions may momentarily exceed the cranes maximum load rating. Overloading the Western Mule Crane may cause the crane to fail or cause serious personal injury and/or death.

DO NOT SIDE LOAD THE WESTERN MULE CRANE. The Crane shall not be used for dragging or pulling loads sideways across a surface. To do so may strain the equipment resulting in its damage and/or failure.

DO NOT alter or modify the Western Mule Crane or any of its components. Do not operate the crane using any form of power other than that which it is specifically intended to use. To do so may reduce the load rating of the crane and/or cause the crane to fail.

SETTING UP VEHICLE AT THE JOB SITE

CAUTION

ONE OF THE MOST IMPORTANT PREREQUISITES TO PROPER SET UP ON JOB SITE IS TO THOROUGHLY PLAN THE LIFT BEFORE POSITIONING THE VEHICLE.

1. Vehicle should be positioned in an area free from obstructions to allow performance of the entire task without repositioning the vehicle
2. The vehicle brakes shall be set.
3. Wheel chocks (blocks) shall be installed before using the Western Mule Crane.
4. **ALWAYS** remove the vehicles keys from the ignition. All keys shall be in the possession of the worker designated to be responsible for the operation of the Western Mule Crane.
5. **INSPECT** the Western Mule Crane before operation. Any defects should be corrected immediately.
6. **ALWAYS** Position tip of boom directly over load to be hoisted.

MAKING THE LIFT

This section is designed to present some of the general precautions that must be taken by the operator when making a lift with the Western Mule Crane.

WEAR a protective hard hat while raising loads.

NEVER stand beneath a load.

DO NOT exceed load limits of the Western Mule Crane as shown on the warning decals.

NOTE: Crane ratings are based upon crane lifting capacity. Not the crane's stability.

MAKING THE LIFT

KEEP tension on the lifting cable at all times.

NEVER wrap lifting cable around load.

NEVER pull the lifting hook or hook eye fittings into the boom sheaves.

ALWAYS center the tip of the boom over the load to be lifted.

NEVER attempt to side load, drag or pull loads across a surface.

NOTE: To do so may strain the crane, resulting in damage and/or failure

ALWAYS maintain a minimum of five (5) wraps of lifting cable on the winch drum.

BE SURE that the load is well secured and properly balanced in the sling or lifting device before it is lifted more than a few inches.

ALWAYS allow the load to come to a full stop before reversing direction.

NEVER raise the load being lifted any higher than needed when moving the load.

KEEP work area clear. **DO NOT** allow unauthorized people in the work area while lifting a load.

NEVER place a chain link on the tip of the lifting hook or attempt to lift a load from the tip of the lifting hook.

DO NOT leave suspended load unattended.

DO NOT attempt any service or repair while the Western Mule Crane is operating.

NEVER use a sling or anything larger than the hook throat that could prevent the latch from closing when lifting a load.

LOAD CHART

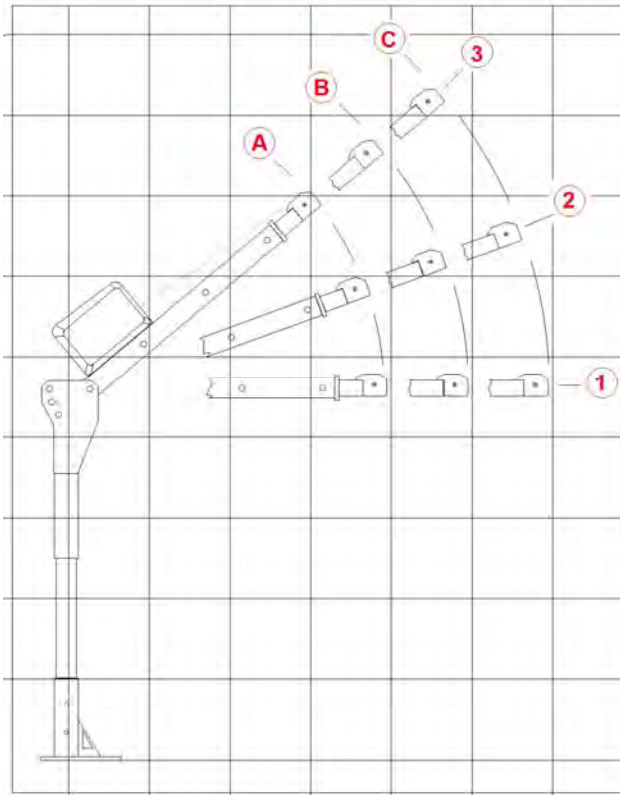

Weight (lbs.)

Boom Position	A	B	C
3	700	600	500
2	700	575	450
1	700	550	400

LEAVING THE JOB SITE

1. Return boom to its stored position, with the boom folded downward.
2. Remove and store the pendant control.
3. Report any unusual occurrence during crane operation that may require maintenance or repair.

⚠ CAUTION

NEVER MOVE VEHICLE WITH THE BOOM IN ITS RAISED POSITION, OR WITH LOAD SUSPENDED FROM IT.

ROTATION BRAKE

The model **P7-VAN** crane is equipped with a Rotation Brake. This feature offers an advantage in many lifting and lowering situations, where it may be desirable to hold the boom in a fixed point of rotation.

When using the Rotation Brake:

NEVER attempt to drag a load or induce any side loading to the boom.

NEVER swing a load suspended from the lifting cable while the Rotation Brake is engaged or at any time while a load is suspended.

NEVER work on a load while it is suspended on the lifting cable.

DO NOT engage the Rotation Brake while the mast/boom are rotating. Always bring the rotation of the mast/boom to a halt and then engage the Rotation Brake.

⚠ CAUTION

MAXIMUM CONTINUOUS RUN TIME OF 4 MINUTES.
CONTINUOUS RUNNING IN EXCESS OF 4 MINUTES EXCEEDS THE DUTY CYCLE OF THE MOTOR AND CAN CAUSE DAMAGE.

AUXILIARY CRANK HANDLE

The model **P7-VAN** crane is equipped with a emergency hand crank handle in the event of power failure.

Remove the plastic plug from the side of the winch housing and insert the handle so that it completely engages with the drive shaft. The handle can be cranked in either direction.

⚠ WARNING

NEVER OPERATE THE WINCH ELECTRICALLY WITH THE EMERGENCY CRANK HANDLE IN PLACE. DOING SO IS DANGEROUS AND **MAY CAUSE INJURY!**

FURTHER SUGGESTIONS

This section is designed to present some of the general precautions that must be taken by the operator when making a lift with the Western Mule Crane.

WEAR a protective hard hat while raising loads.

NEVER stand beneath a load.

DO NOT exceed load limits of the Western Mule Crane as shown on the warning decals.

NOTE: Crane ratings are based upon crane lifting capacity. Not the crane's stability.

ALWAYS use the outrigger (support leg) from the bumper to the ground during crane operation. Insure that it is firmly positioned on a solid footing.

ALWAYS secure the support arm to the mast with the fast pin.

KEEP tension on the lifting cable at all times.

NEVER wrap lifting cable around load.

DO NOT stand between the load and the vehicle.

NEVER pull the lifting hook or hook eye fittings into the boom sheaves.

ALWAYS center the tip of the boom over the load to be lifted.

NEVER attempt to side load, drag or pull loads across a surface.

NOTE: To do so may strain the crane, resulting in damage and/or failure.

ALWAYS maintain a minimum of five (5) wraps of lifting cable on the winch drum.

KEEP tension on the lifting cable at all times.

FURTHER SUGGESTIONS

BE SURE that the load is well secured and properly balanced in the sling or lifting device before it is lifted more than a few inches.

ALWAYS allow the load to come to a full stop before reversing direction.

NEVER raise the load being lifted any higher than needed when moving the load.

KEEP work area clear. **DO NOT** allow unauthorized people in the work area while lifting a load.

NEVER place a chain link on the tip of the lifting hook or attempt to lift a load from the tip of the lifting hook.

DO NOT leave suspended load unattended.

DO NOT tow another vehicle with the crane.

DO NOT attempt any service or repair while the Western Mule Crane is operating.

NEVER use a sling or anything larger than the hook throat that could prevent the latch from closing when lifting a load.

PREPARING FOR INSTALLATION

⚠ CAUTION

THE MANUFACTURER CANNOT FORESEE THE MANY VARYING TYPES OF PLATFORMS THAT INSTALLATIONS MAY BE PERFORMED ON. EACH INSTALLATION SHOULD BE EVALUATED BEFOREHAND TO ENSURE THAT THE STRUCTURAL INTEGRITY IS SUFFICIENT TO HANDLE THE EXTRA WEIGHT OF THE WESTERN MULE CRANE MOUNTED ON THE VEHICLE AND THE LOADS BEING LIFTED BY THE CRANE.

The **P7-VAN** crane can be mounted on any pickup, flat bed truck, trailer, and utility body or in a cube van in sound condition.

BEFORE installing the Western Mule Crane, consult applicable codes and regulations for specific instructions and rules regarding the installation of mobile cranes.

DO NOT install the Western Mule Crane in an area that contains corrosive chemicals, combustible materials, explosives or other elements which may cause property damage, serious personal injury and/or death.

DO NOT install the Western Mule Crane on a vehicle or platform that is not in good sound mechanical working condition.

BEFORE placing the Western Mule Crane into service, thoroughly inspect it.

INSTALLATION

1. Un-box the Western Mule Crane and check the packing slip to verify the contents.
2. Determine where the Western Mule Crane is to be mounted, insuring that the structural integrity is sufficient to handle the loads that the vehicle or platform will be subjected to while lifting with the crane.
3. Position mounting base in desired location for handling your load needs. Take inconsideration where the boom will be stored.
4. Try to anticipate the size of the object to be loaded and load placement.

INSTALLATION

5. It will be necessary to reinforce the underside of the truck bed, bumper, or platform that the crane is being mounted upon. One method is using a bottom plate 3/8" thick or larger, mounted to the underside of the bed, under the crane base plate. The bottom plate should be large enough to cover the 4 holes in the mounting base of the crane and long enough to reach the vehicle frame. Each application will vary.
6. Before drilling holes in the bed, check underside of bed for location of frame and cross members. Mark and drill holes using base plate as the guide. (**BEFORE DRILLING HOLES**, be sure and avoid wiring, brake and fuel lines, and fuel tanks)
7. Fasten the crane to the vehicle or platform, using no less than 9/16" grade 8 bolts.
(Refer to table, page 18 for torque specifications)
8. Route the longest of the two power lead wire from the crane to the circuit breaker at the battery. Secure to frame using wire ties. Avoid routing next to fuel lines, brake lines, fuel tank, exhaust system, or any moving parts. Allow enough extra wire at crane for rotation of crane.
9. Attach circuit breaker to positive lead and to positive side of battery.

CAUTION

DO NOT TIE WIRE TO ANY PART OF FUEL SYSTEM OR BRAKE SYSTEM. KEEP WIRE AWAY FROM HOT OR MOVING PARTS.

DO NOT OPERATE WINCH WITHOUT CIRCUIT BREAKERS OR DO NOT BYPASS BREAKERS. BYPASSING CIRCUITS CREATES A FIRE HAZARD AND IS DANGEROUS TO THE PERSONAL SAFETY OF THE OPERATOR

10. Route ground wire to the chassis or battery and attach securely. Allow enough extra wire at the crane to the bed for the crane to rotate. Secure the wires so as they do not make contact with any hot or moving parts.
11. Inspect crane fully before placing in operation
12. Your crane is now ready for operation. Refer to operation section of this manual before operating. Read it carefully and follow all instructions for proper and safe procedures.

Inspect crane fully before placing in operation.

BOLT TORQUE SPECIFICATIONS

Table 1

UNC Size	Grade 8 Tightening Torque
9/16" - 12	150 +/- 15
5/8" - 11	215 +/- 15

NOTE: Torque values are in foot-pounds. Torque values specified are with residual oils or no special lubricants applied to the bolts. If special lubricants of high stress ability, such as never-seize compound, graphite, oil or molybdenum disulfide, etc. are used multiply the torque figures in the chart by a factor of .90.

Torque values for bolts listed above are not affected with the use of Loctite or similar product. Hardened washers should be used with Grade 8 or better bolts.

▲ CAUTION

ALWAYS WEAR SOME FORM OF HAND PROTECTION. LIFTING CABLE CAN CAUSE SERIOUS INJURY TO YOUR HANDS.

WIRING DIAGRAM

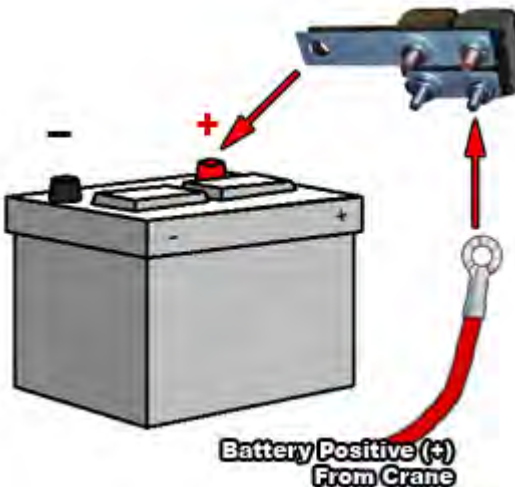

DAILY INSPECTION

WARNING

SAFE OPERATION **DEPENDS ON YOU**, THE CONDITION OF YOUR EQUIPMENT AND YOUR MAINTENANCE AND INSPECTION PROCEDURES.

The single most important factor in the prevention of equipment failures and accidents is a positive attitude towards safety. The habit of anticipating possible problems normally prevents many accidents from occurring.

The crane shall be inspected by the user daily before each use and additionally by a competent person other than the user at periodic intervals.

Inspection checks **must be** performed. On the following page are several important inspections that should be performed before and during **each** operation of the Western Mule Crane. Inspection checks **must be** performed. Below are several important inspections that should be performed before and during **each** operation of the Western Mule Crane.

1. **FASTENERS** – visually check all pins, retainers, bolts, and nuts. Check for presence and proper tightness.
2. **SHEAVES** – check for lifting cable wear, cracks and ease of rotation. If they do not turn freely or the bushings in the sheaves are worn, replace them immediately.
3. **LIFTING CABLE** – check for frayed edges, broken strands, kinks, and flat spots. If damaged, replace before use. *(See page 21 for cable inspection procedures)*
4. **WINCH** – check lifting cable for proper spooling on the winch drum.
5. **CRANE HOOKS** – check hook and safety catch, for twist or distortion. *(See page 21 for hook inspection procedures)*
6. **OPERATING PLACARDS AND SAFETY DECALS** – check for missing, illegible, defaced decals and placards.
7. Make necessary repairs of the above items and/or replacements before operating the Western Mule Crane.

Continued next page...

DAILY INSPECTION

...Continued from previous page

D & S Sales recommends and government regulations require that an employer shall perform frequent and periodic inspections and maintain results of these inspections for each Western Mule Crane and that a competent person shall make a thorough annual inspection of the crane. The employer shall maintain a record of the dates and results of the inspections for each crane and its optional equipment.

WARNING

DO NOT OPERATE THE WESTERN MULE CRANE IF SIGNS OF DAMAGE OR POOR OPERATION, ARE NOTICED TO DO SO MAY RESULT IN PROPERTY DAMAGE, SERIOUS PERSONAL INJURY AND/OR DEATH. PLACE A “**DO NOT USE CRANE OUT OF ORDER**” SIGN ON THE WESTERN MULE CRANE AND IN THE VEHICLE. DO NOT USE UNTIL THE WESTERN MULE CRANE IS REPAIRED AND A QUALIFIED MAINTENANCE PERSON WHO HAS SEEN TO THE COMPLETE CORRECTION OF THE PROBLEM AND INSPECTION OF THE CRANE, REMOVES THE SIGNS.

INSPECTION OF LIFTING CABLE AND HOOK

Many variable factors can cause the deterioration of the lifting cable that it is not possible to pre-determine a definite life expectancy.

Some of the contributing factors are:

1. Load being lifted
2. Corrosive conditions
3. Maintenance of the Western Mule Crane
 - a. Sheaves not turning freely
 - b. Improper spooling on winch drum.
 - c. Kinks in lifting cable
 - d. Abrasive action and contact with sharp corners.
4. Storing crane with lifting cable excessively tight.
5. Frequency of use

Keeping the working load ratings in mind and knowing the kind of loads that will be handled, the user can determine by inspection of the lifting cable as to when the lifting cable should be replaced.

Items to look for while inspecting lifting cable are:

1. Broken strands
2. Kinks and flattened sections
3. Corrosion and abrasion
4. Distortion of the lifting cable, such as kinking, crushing, etc.

Items to look for while inspecting the lifting hook are:

1. Bent or twisted hook
2. Damaged or non-operable safety latch
3. Hook is securely attached to the lifting cable

WARNING

STOP USING THE HOIST AND REPLACE THE LIFTING CABLE OR HOOK IF ANY OF THE DEFECTS LISTED ARE FOUND.

CABLE REPLACEMENT

The lifting cable must be installed and spooled as shown in the illustration below, or the brake **MAY NOT FUNCTION**.

If it becomes necessary to replace the lifting cable, use only the minimum recommended cable size for your crane model noted on the cranes serial number plate.

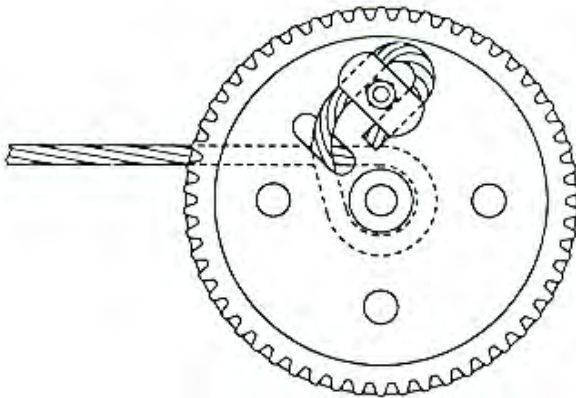

When inserting the lifting cable into the drum, insert it into the correct end of the hole as shown above. Tighten the set screw securely.

With the end of the cable securely installed, carefully wind the length of the lifting cable onto the drum.

▲ CAUTION

ALWAYS WEAR SOME FORM OF HAND PROTECTION. LIFTING CABLE CAN CAUSE SERIOUS INJURY TO YOUR HANDS.

P10 RREPLACEMENT PARTS

When ordering parts, please supply your crane's model and serial number. Parts may be obtained through your local dealer or distributor.



Note: Photo shows model P10-DC, which shares the same parts as model P7-VAN.

WINCH PARTS

When ordering, please supply your crane's model and serial number.
Parts may be obtained through your local dealer or distributor.

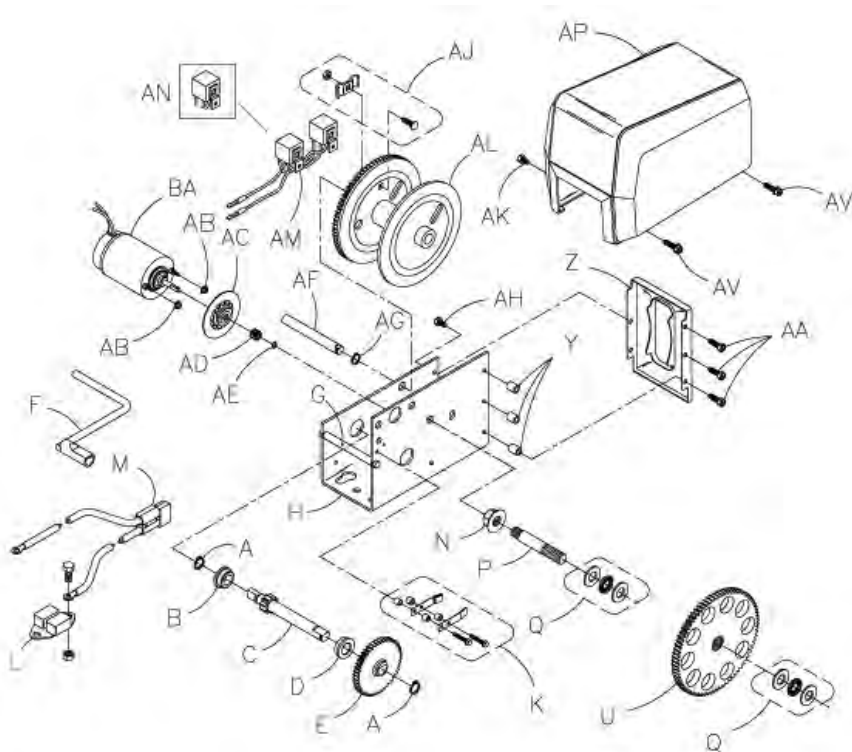

<u>Ref. Part</u>	<u>Number</u>	<u>Ref. Part</u>	<u>Number</u>	<u>Ref. Motor Part</u>	<u>Number</u>
A Retaining Ring (2)	205191	AA Screw - 1/4 - 20x5/8 (3)	205238	BA Motor Assy.	304349
B Bushing	204012	AB Locknut, 10-32 (2)	205193	L Circuit Braker	304025
C Drive Shaft Assy.	304813	AC Brake Disc Assy.	304407	M Power Cord w/ Plug	304744
D Bushing	204009	AD Motor Pinion	404522	P Shaft	404517
E 56T Gear	204703	AE "E" Ring	205135		
F Auxiliary Handle Assy.	304412	AF Reel Shaft	404559		
G Base Spacer	404557	AG Retaining Ring	204468		
H Base	404922	AH Screw, 1/4 - 20x3/8 (2)	205337		
K Brake Spring Replacement Kit	6380	AJ Cable Clamp Kit	6285		
N Locknut	205192	AK Screw, 1/4 - 20x3/4 (2)	205338		
Q Thrust Bearing Replacement Kit (Includes Item X)	6381	AL Reel Assy.	304812		
		AM Relay Assy. (2 Relays + Jumpers)	304972		
U 120T Gear Assy.	304409	AN Relay (1)	304972-2		
Y Front Plate Spacer (3)	404562	AP Cover	404563		
Z Front Plate	404553	AV Screw, 1/4 - 20x7/8 (2)	205242		

GENERAL INFORMATION

The WESTERN MULE CRANE, model **P7-VAN** is designed to handle loads up to 700 lbs. and rotate right or left 360 degrees, non-continuous.

You **MUST** change rotation direction to keep from damaging the electric power wiring.

Practice using the crane with lighter loads, until you become familiar with the safe operation of the crane.

DO NOT overload the Western Mule Crane or exceed the load rating of the weakest component in the system (I.E. the lifting cable, sling, lifting attachment, etc.). Overloading may result in damage and/or failure of the equipment, which may lead to serious personal injury and/or death.

DO NOT SIDE LOAD THE WESTERN MULE CRANE. The Crane shall not be used for dragging or pulling loads sideways across a surface. To do so may strain the equipment resulting in its damage and/or failure.

DO NOT alter or modify the Western Mule Crane or any of its components. Do not operate the crane using any form of power other than that which it is specifically intended to use. To do so may reduce the load rating of the crane and/or cause the crane to fail.

MAKE SURE that at least a minimum of 5 wraps of lifting cable remain on the winch drum at all times in order for the lifting cable to remain securely anchored to the winch drum.

ALWAYS return the Western Mule Crane to its stored position before moving vehicle.

REPLACEMENT PARTS

When ordering, please supply your crane's model and serial number. Parts may be obtained through your local dealer or distributor.

PRODUCT REGISTRATION

Every effort is made to supply product updates and other information relevant to the use of this crane. To register your crane, we request that you do this online on our *Support Page* at westernmule.com click on *Warranty Registration* at the top of the page. If you do not have internet access, please fax or mail the enclosed warranty registration card.

WESTERN MULE CRANES

1510 Merced Street
Fresno, CA 93706
Phone (559)266-6977



FOLD - A - WAY
CRANE

1 YEAR LIMITED WARRANTY

The manufacture, warrants to the original retail purchaser it's product, the Western Mule, for twelve months (one year) from the date of delivery that your new Western Mule Crane is free from defects in material and workmanship if properly set up and operated in accordance with the recommendations set forth in the Western Mule Owner's Manual. If a date cannot be established, then the date the product was sold by the Distributor will be used.

Obligation of the manufacture, under this warranty, is expressly limited to the replacement or repair of parts, which prove defective in material or workmanship for the duration of this warranty. To make a claim under this warranty, the product must be returned, freight prepaid to the manufacture. The sole measure of damages shall be limited to the price of defective parts.

This warranty does not obligate the manufacture to bear the cost of labor in the field or transportation charges in connection with replacement or repair of defective parts.

Factory authorized repair or replacement as provided under this warranty is the exclusive remedy to the consumer. The manufacture shall not be liable for any incidental or consequential damages or for breach of any express or implied warranty on this product.

Any damage to the Western Mule, as a result of abuse, misuse, overloading, negligence, accidents, improper installation or any unauthorized alteration, repair or modifications made without written authorization by the manufacturer or any act that violates the instructions furnished by the manufacture, will void the warranty.

NO representative of the manufacture has the authority to amend or modify the warranty or to bind the company by any other warranty, guarantee or assumption of liability. There are no warranties, which extend beyond the above description and it is expressly understood and agreed that no warranty of merchantability or warranty of fitness for particular purpose, or other warranty express, implied or statutory is made.

FREIGHT CHARGES - This warranty does not cover freight charges incurred to return defective parts to the manufactures location or the shipment of replacement parts to the warranty holder.

EXCLUSION - There is no warranty on the lifting cable against breakage or fraying.

Certain limitations expressed herein are excludable in accordance with provisions of local law. Such limitations shall be deemed struck if such law is applicable. All other limitations and provisions shall continue to apply.

MANUFACTURED AND DISTRIBUTED BY

Western Mule Cranes

1510 Merced Street

Fresno, CA 93706 USA

Ph: 559-266-6977 Fax: 559-266-7437

E-Mail: cranes@westernmule.com

www.westernmule.com

Western Mule Cranes reserves the right under its product improvement policy to change construction or design details and furnish equipment when so altered without reference to illustrations are specifications used.

Made in the U.S.A.