

40640 Instructions

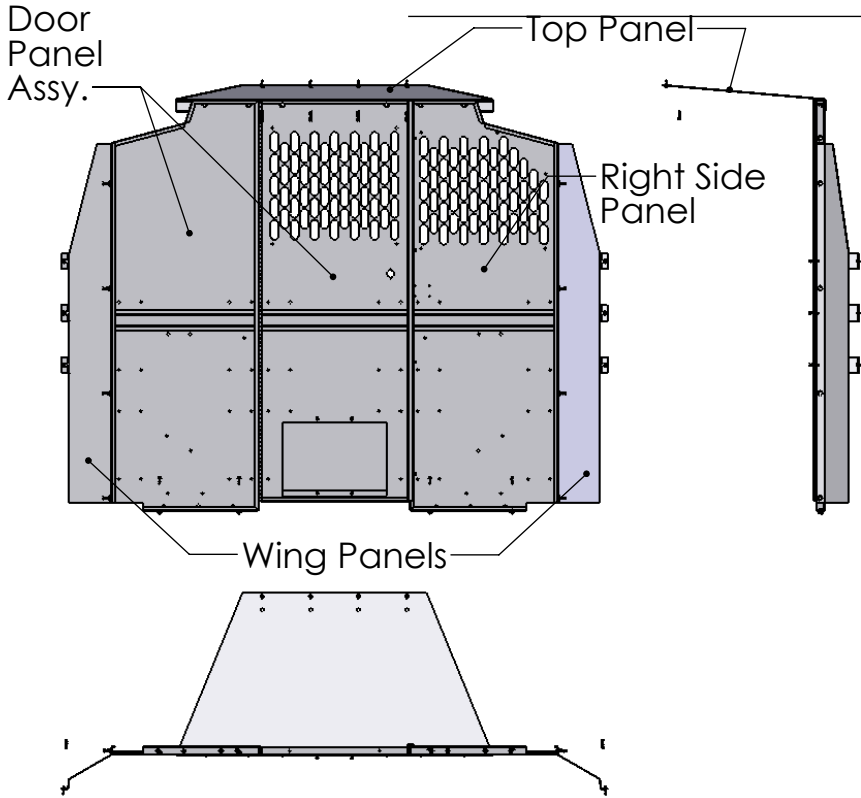

1) Bolt Door panel Assembly to right side panel, using 2 1/4" flat washers between the panels as spacers if you are using the door. If you are not using the door you can bolt them directly together. (4- 1/4" Carriage bolts)

2) Bolt top panel to the door panel and right side panel assembly. (6- 1/4" Carriage Bolts)

3) Bolt wing panels to center panel assembly. (8- 1/4" Carriage Bolts)

4) Position partition into desired location (usually up against the seats with them pushed all the way back), making sure that bolt hole locations line up with a structural part of the van. Use a straight edge along the bottom to keep panels inline. Mark paneling and cut as need to allow mounting tabs to touch the metal surface.

5) If you are using self tapping screws, then screw the partition in place. If you are using Plus-nuts, mark the locations, drill pilot holes and install Plus-nuts.

NOTE: USE DRILL STOP TO AVOID DAMAGE!

6) If you have a rubber floor mat, you need a 1" hole saw to cut a hole in the mat for the 3/8"x1" spacer to fit into.

7) Bolt unit in place.

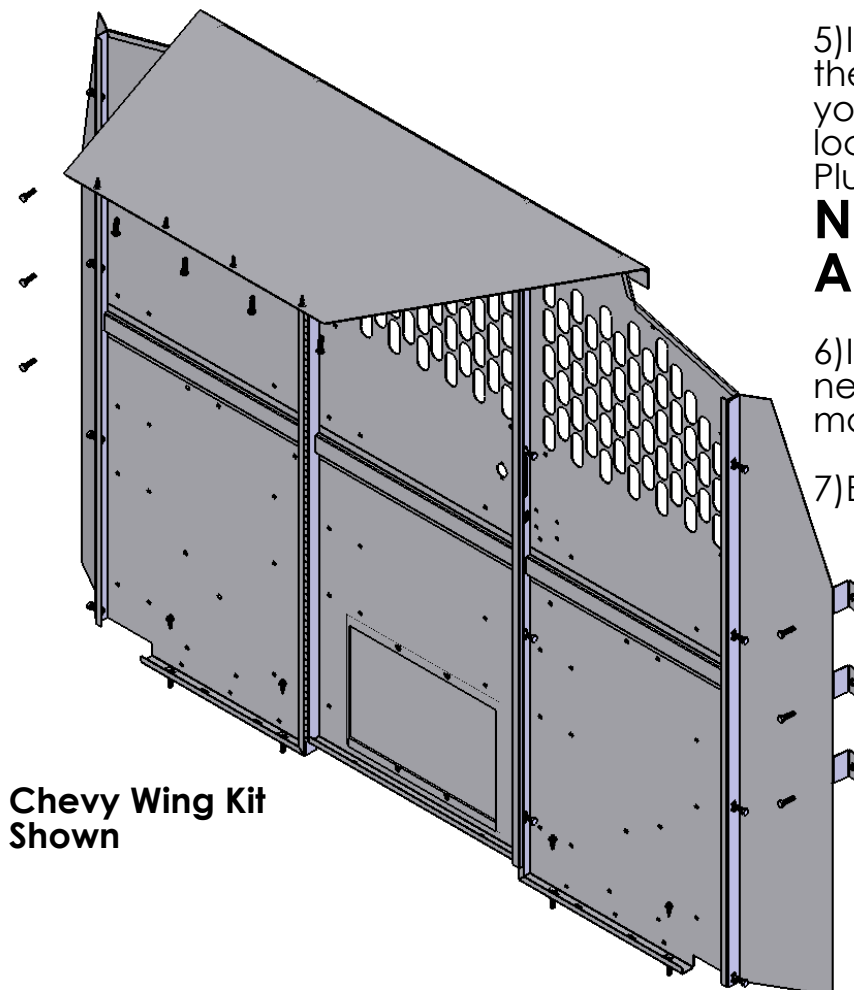

Chevy Wing Kit Shown