

Thank you for purchasing the Rack-Strap® Ladder Lock, the ultimate theft deterrent system for your ladders. The versatile Ladder Lock easily adjusts to secure 1 or 2 ladders.

Built with high quality materials, the Ladder Lock is not only strong, but has a professional appearance. The Ladder Lock is zinc plated with a yellow chromate finish for superior weather and road salt protection, and includes a lock guard to protect against road grime. The carborized steel arm resists saw blades, and the internal lock pin is not vulnerable to bolt cutters. The Ladder Lock permanently mounts to the rack, always ready to use, right where it is needed. The steel arm can be easily repositioned and locked in place parallel to the rack when not in use, allowing other materials to be carried on the rack. With Ladder Lock, it takes only seconds to secure your ladders, saving valuable labor time and protecting your equipment from theft.

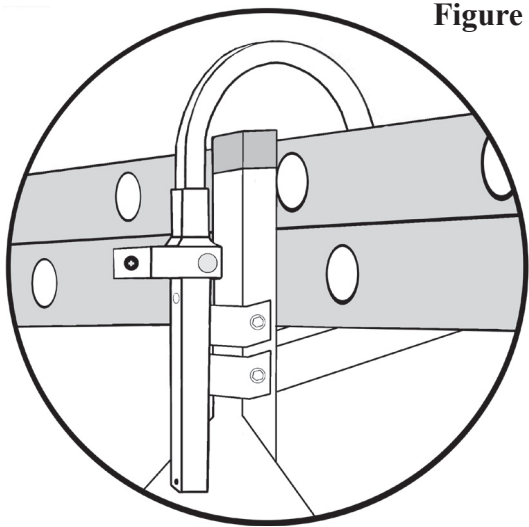
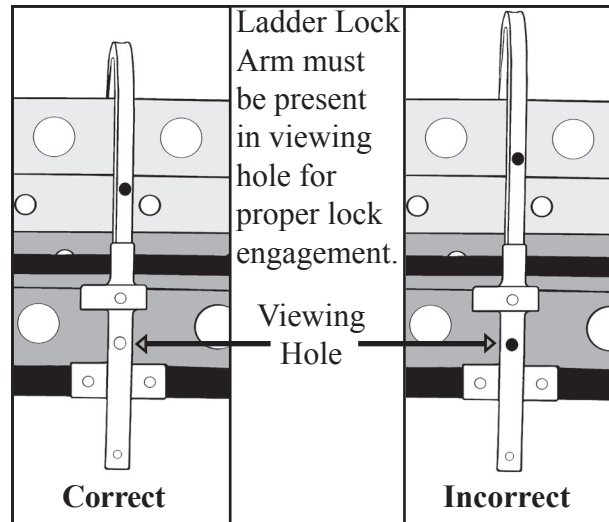

Figure 1

* Use Only As Illustrated *

SECURING LADDERS. After ladders are loaded, position Ladder Lock arm in the proper locking position perpendicular to the rack as illustrated in Figure 1. Push in the lock pin and remove the key. Ladder Lock arm should always be present in viewing hole when lock is engaged as illustrated in Figure 2. Place lock cover in down position when not locking or unlocking. Always use a proper tie-down, such as Rack-Straps®, in addition to the Ladder Lock to prevent shifting, vibration or movement of your ladders.

Figure 2



When No Ladders Are Loaded, always keep the ladder lock in the correct resting position parallel to the rack and within the length of the vehicle as illustrated in Figure 3. Never position the ladder lock arm outward from the vehicle as illustrated in Figure 4.

Figure 3

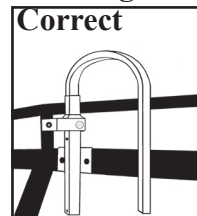
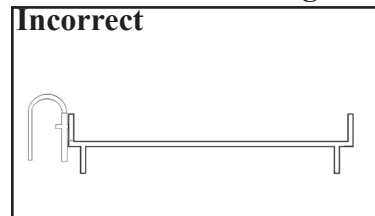

Figure 4



Instructions for Mounting Your Ladder Lock

Note: Manufacturer suggests Ladder locks be welded in position for maximum security.

To Mount Using Bolts: Place Ladder Lock in position on the rack and mark holes for drilling. Drill holes in post and mount Ladder Lock as illustrated in Figure 5. Proper height alignment should allow 13 inches from rack cross member to the inside surface of arm at the apex of the bend when in 2 ladder position. Apply permanent thread locker according to manufacturer's instructions and fasten nut. Repeat until all Ladder Locks have been securely attached.

MATERIALS FOR BOLTING:

Materials required to install one Rack-Strap® Ladder Lock:

- 2 - 3/8" bolt of the proper length, Grade 8
- 1 - Tube permanent thread locker
- 4 - 3/8" cut washers
- 2 - 3/8" lock washers
- 2 - 3/8" nuts

Figure 5

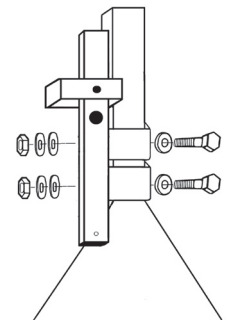

Tools Required:

- 1 - Drill
- 1 - 13/32" metal drill bit
- 2 - 3/8" wrench
- 1 - Tape measure

POSITIONING. Mount Ladder Locks on vertical post directly behind driver and/or passenger doors as illustrated in Figure 6.

Figure 6

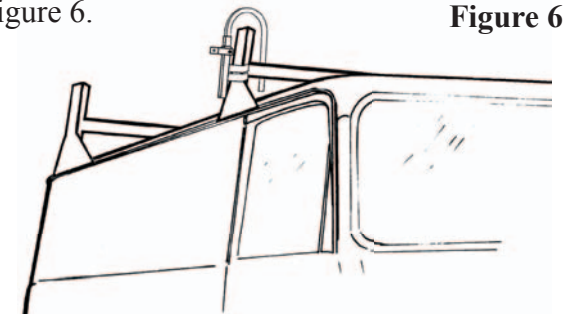

Limited Warranty

We warrant to the original purchaser of the Rack-Strap® Ladder Lock manufactured by us, to be free from defects in material and workmanship under normal use and service. Our obligation under this warranty shall be limited to the repair or exchange of any part or parts which may thus prove defective under normal use and service within thirty (30) days from date of purchase by the original purchaser, and which our examination shall disclose, to our satisfaction, to be thus defective.

THIS WARRANTY IS EXPRESSLY IN LIEU OF ALL OTHER WARRANTIES EXPRESSED OR IMPLIED, INCLUDING THE WARRANTIES OF MERCHANTABILITY AND FITNESS FOR USE AND OF ALL OTHER OBLIGATIONS OR LIABILITIES ON OUR PART, AND WE NEITHER ASSUME NOR AUTHORIZE ANY OTHER PERSON TO ASSUME FOR US, ANY OTHER LIABILITY IN CONNECTION WITH THE SALE OF THIS RACK-STRAP® LADDER LOCK OR ANY PART THEREOF WHICH HAS BEEN SUBJECT TO ACCIDENT, NEGLIGENCE, ALTERATION, ABUSE, OR MISUSE. WE MAKE NO WARRANTIES WHATSOEVER IN RESPECT TO ACCESSORIES OR PARTS NOT SUPPLIED BY US. THE TERM "ORIGINAL PURCHASER", AS USED IN THIS WARRANTY, SHALL BE DEEMED TO MEAN THAT PERSON TO WHOM THE RACK-STRAP® LADDER LOCK WAS ORIGINALLY SOLD. THIS WARRANTY SHALL APPLY ONLY WITHIN THE BOUNDARIES OF THE CONTINENTAL UNITED STATES OF AMERICA.

RACK-STRAP® INC.

www.RackStrap.com

2750 INDUSTRIAL AVE
HUBBARD, OR 97032

800-841-5790
Ph: 503-982-1920
Fax: 503-982-7022

Cautions

The Rack-Strap® Ladder Lock was designed to be a superior theft deterrent system for ladders. However, preventative maintenance must be performed and common sense must be used. The following is a partial list of considerations which may help with your use of the Rack-Strap® Ladder Lock.

- Inspect the entire system frequently.
- Check mounting welds and/or bolts frequently. Tighten bolts when necessary.
- Use only replacement parts manufactured by Rack-Strap®, Inc.
- Keep lock cover in the down position when not locking or unlocking the unit to keep housing and lock clear of all debris and in good working condition. Occasional application of a light lubricant to lock will contribute to proper lock performance.
- Never Mount Ladder Locks on the recessed portion of forklift side loading racks.
- Engage the Ladder Lock only as illustrated.
- Ladder Lock may increase the height of your vehicle.
- Never position Ladder Lock arm outward from vehicle.
- Ladder Lock is a theft deterrent device. It is not intended for use as a tie-down. Proper tie-downs, such as the Rack-Strap®, should be used in combination with the Ladder Lock.

RACK-STRAP® Ladder Lock

www.RackStrap.com

