

P10 SERIES

Lifting Capacity: 1,000 lbs.
 Boom Length Extended: 5 ft.

Featuring a lightweight, portable design, for mounting into pickups, service bodies, vans, loading docks, platforms, etc.

Compact, weighing only 132 lbs. installed, with a fold-down boom design for storage and requiring minimal mounting space.

Versatile design with 12V-DC, 120V-AC or Manual Hand Crank operated models. Optional Mast Heights, Mounting Bases, and Accessories are also available.

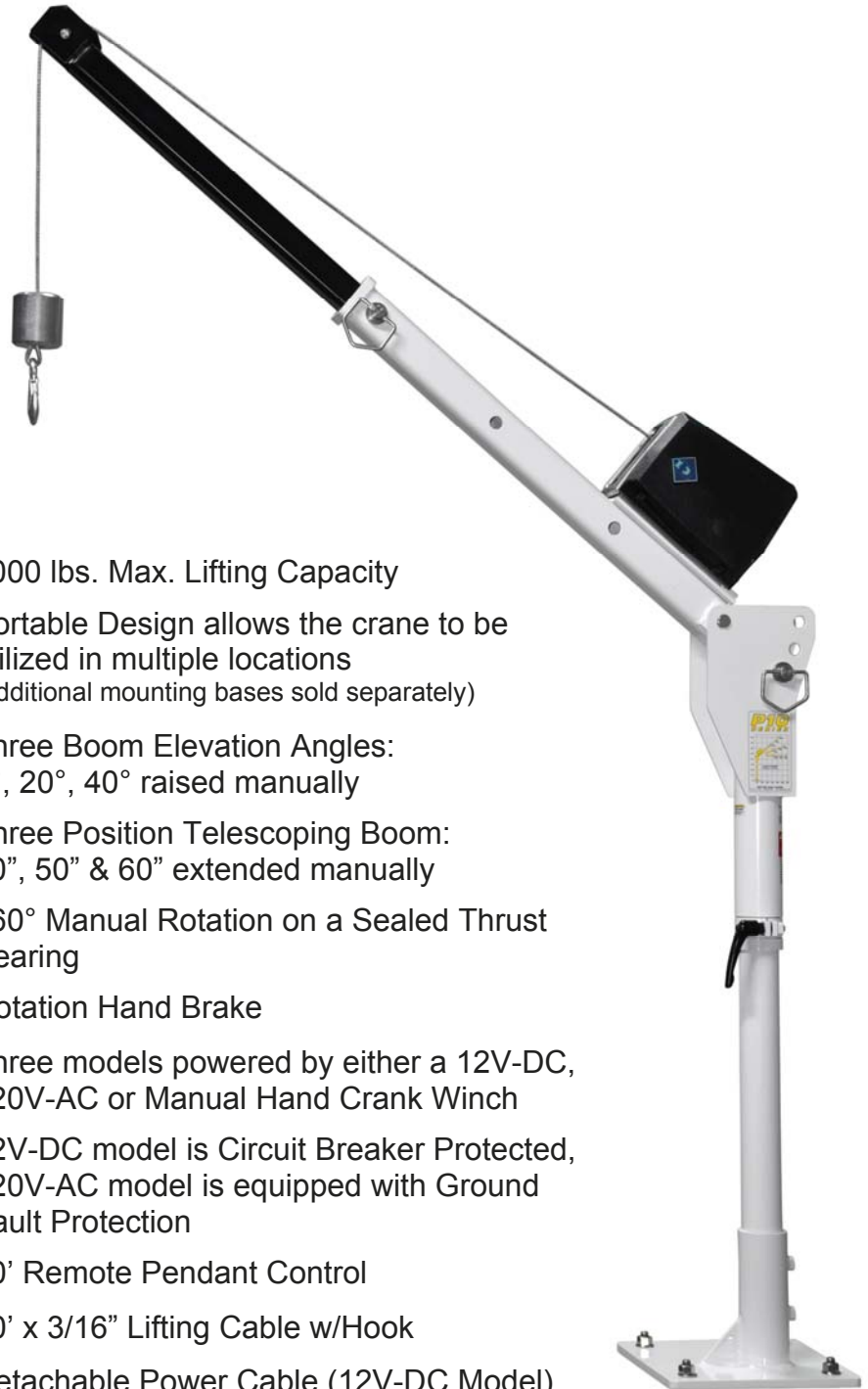

- ▶ 1000 lbs. Max. Lifting Capacity
- ▶ Portable Design allows the crane to be utilized in multiple locations (additional mounting bases sold separately)
- ▶ Three Boom Elevation Angles: 0°, 20°, 40° raised manually
- ▶ Three Position Telescoping Boom: 40", 50" & 60" extended manually
- ▶ 360° Manual Rotation on a Sealed Thrust Bearing
- ▶ Rotation Hand Brake
- ▶ Three models powered by either a 12V-DC, 120V-AC or Manual Hand Crank Winch
- ▶ 12V-DC model is Circuit Breaker Protected, 120V-AC model is equipped with Ground Fault Protection
- ▶ 10' Remote Pendant Control
- ▶ 20' x 3/16" Lifting Cable w/Hook
- ▶ Detachable Power Cable (12V-DC Model)
- ▶ Durable White Powder Coat Finish
- ▶ 1-Year Warranty (excluding lifting cable)

Optional mast heights, mounting bases, and custom configurations also available.

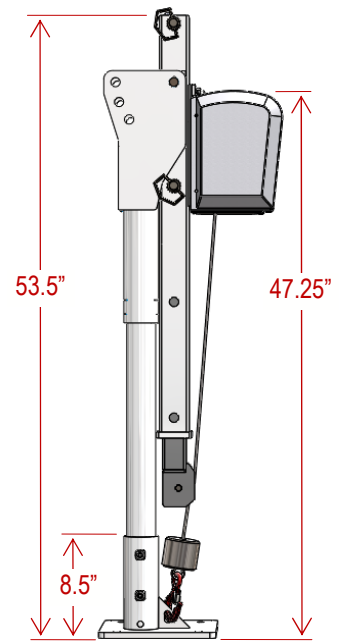
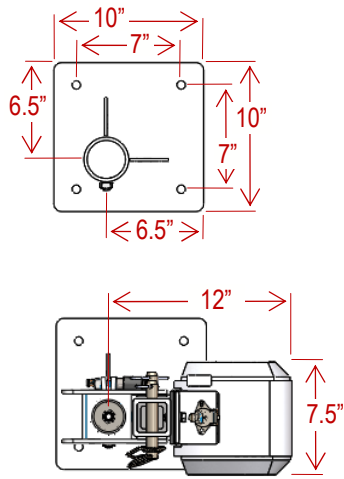
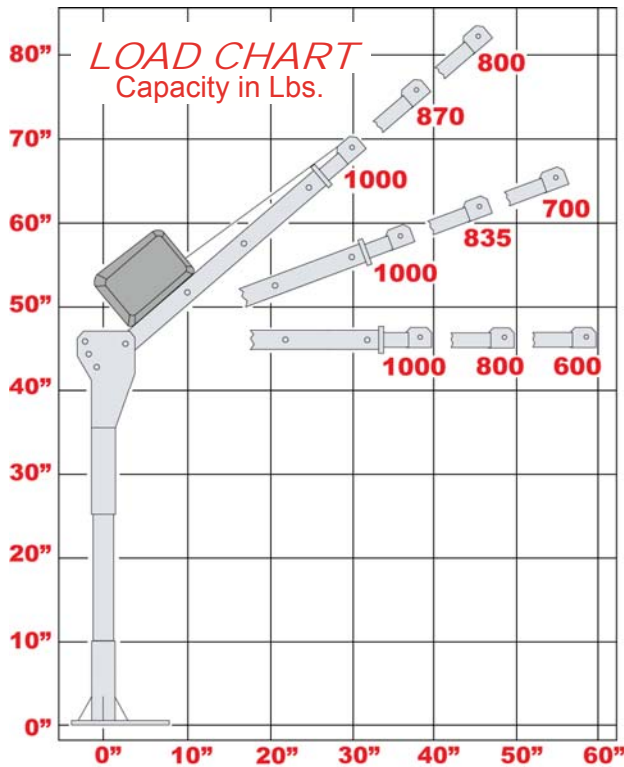

Optional mast heights, mounting bases, and custom configurations available.

STANDARD FEATURES

MODEL:	P10-DC	P10-AC	P10-MN
Lifting Capacity (maximum)	1000 lbs.	1000 lbs.	1000 lbs.
Lifting Height Max. Std. (base to hook)	72"	72"	72"
Storage Height Folded (from base)	53.5"	53.5"	53.5"
Reach Max. (from center of rotation)	60"	60"	60"
Rotation (continuous) with Brake	360° Manual	360° Manual	360° Manual
Lifting Cable	20' x 3/16"	20' x 3/16"	20' x 3/16"
Line Speed (feet/min) No Load / Load	16 / 6	17 / 8	Manual Crank
Power Requirements	12V-DC 70 amps	120V-AC 6 amps	Manual
Controls	10' Remote (Detachable)	10' Remote	none
Mounting Base	10" x 10"	10" x 10"	10" x 10"
Mounting Bolt Hole Pattern	7" x 7"	7" x 7"	7" x 7"
Finish	White Powder-Coat	White Powder-Coat	White Powder-Coat
Weight of Crane / Shipping Weight (Lbs)	132 / 170	132 / 170	121 / 154
Warranty (excluding lifting cable)	1-Year	1-Year	1-Year

OPTIONS

Part #	Description
WP-120	12" Taller Mast (increases height 12")
WP-240	24" Taller Mast (increases height 24")
WP-22	50' x 3/16" Lifting Cable (upgrade from 20')
WA-34	Fold-Down Adjustable Outrigger
WP-110	Extra Mounting Base - (Standard)
WP-114	Extra Mounting Base - (Inverted)

Note: Standard mounting base is included with each crane.

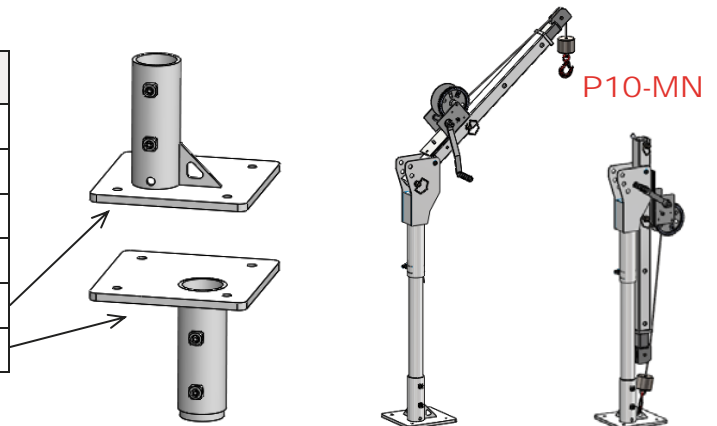

We reserve the right under the Product Improvement Policy to change specifications without notice or reference to specification used herein.

R217

