

ASSEMBLY INSTRUCTIONS
for :

PRO-II SERVICE BODY

Parts: 70020 & 70023

Ver.3

KARGO[®]
MASTER

(916) 638-8703

(800) 343-7486

• 11261- G Trade Center Drive • Rancho Cordova, CA 95742 •

ASSEMBLY INSTRUCTIONS

Read all instructions carefully and follow each step in proper sequence for ease and speed in assembling your **KARGO-MASTER RACK**. See nuts and bolts diagram.

PRO II - SERVICE BODY

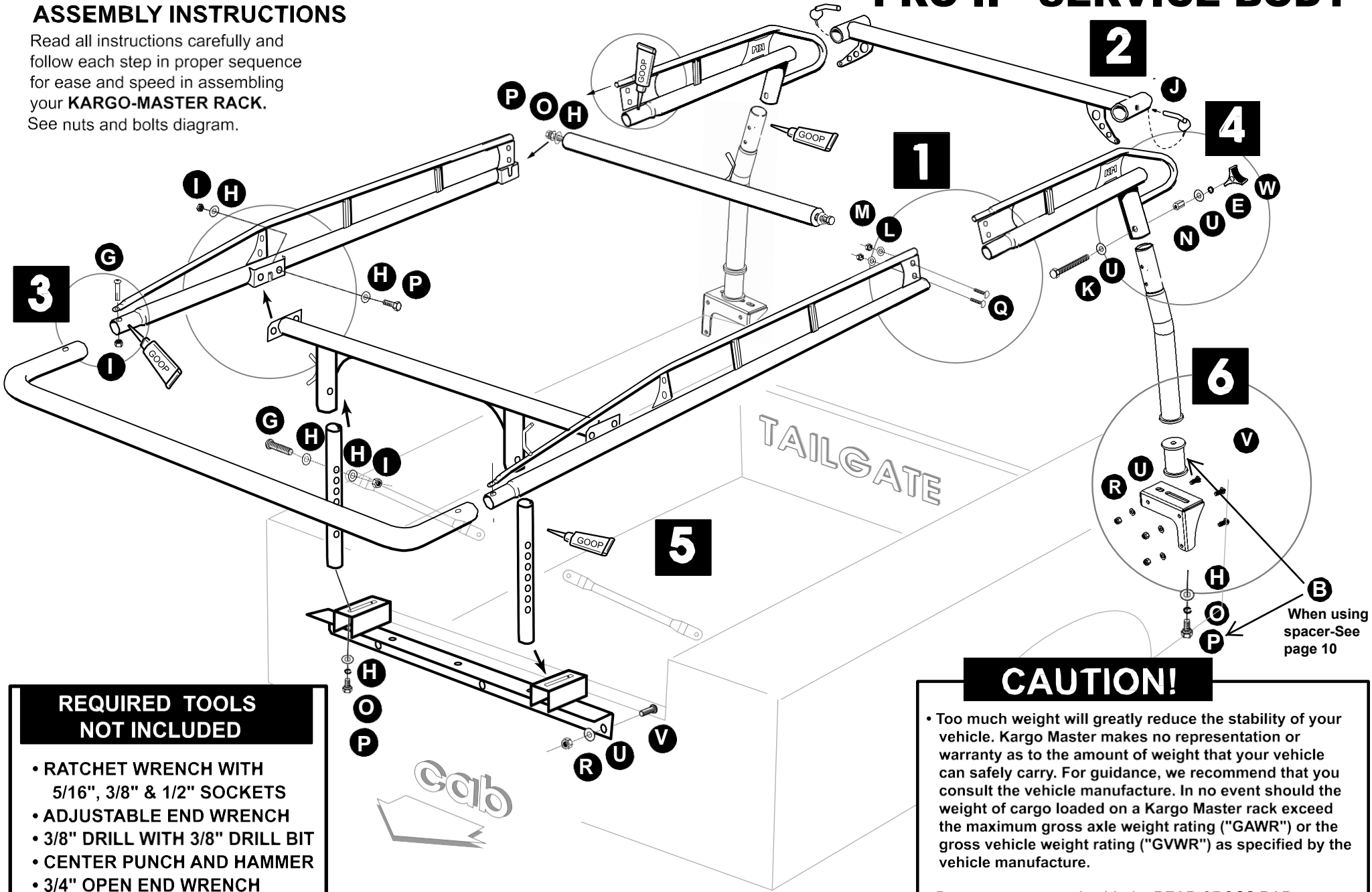

- REQUIRED TOOLS NOT INCLUDED**
- RATCHET WRENCH WITH 5/16", 3/8" & 1/2" SOCKETS
 - ADJUSTABLE END WRENCH
 - 3/8" DRILL WITH 3/8" DRILL BIT
 - CENTER PUNCH AND HAMMER
 - 3/4" OPEN END WRENCH

CAUTION!

- Too much weight will greatly reduce the stability of your vehicle. Kargo Master makes no representation or warranty as to the amount of weight that your vehicle can safely carry. For guidance, we recommend that you consult the vehicle manufacture. In no event should the weight of cargo loaded on a Kargo Master rack exceed the maximum gross axle weight rating ("GAWR") or the gross vehicle weight rating ("GVWR") as specified by the vehicle manufacture.
- Do not use your rack with the REAR CROSS BAR removed. The structural integrity will be affected.
- Secure all payloads properly for safe transportation.



70020 Hardware List

Tools Needed

8' Tape Measure

1/2" Socket

1/2" End Wrench

5/16" Socket

5/16" End Wrench

Hardware Pack

(G)

Qty 4 -

1/2" x 2-3/4" Button Head Allen Bolt



(K)

Qty 2 -

3/8" x 3-1/2" Hex Bolt



(P)

Qty 12 -

1/2" x 1-1/4" Hex Bolt



(Q)

Qty 8 -

5/16" x 3/4" Carriage Bolt



(V)

Qty 10 -

3/8" x 1" Button Head Allen Bolt



(N)

Qty 2 -

3/8" Coupling Nut



(W)

Qty 2 -

Plastic Knob

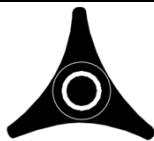

(D)

Qty 10 -

5/16" x 1" Hex Bolt



(C)

Qty 2 -

1/2" x 3-1/4" Button Head Allen Bolt



(E)

Qty 11 -

3/8" Lock Washer



(O)

Qty 12 -

1/2" Lock Washer



(H)

Qty 20 -

1/2" Flat Washer



(L)

Qty 29 -

5/16" Flat Washer



(U)

Qty 17 -

3/8" Flat Washer



(I)

Qty 12 -

1/2" Nyloc Jam Nut



(M)

Qty 18 -

5/16" Nyloc Nut



(R)

Qty 9 -

3/8" Nyloc Nut



(B)

Qty 2 -

1/2" x 4-1/2" Hex Bolt

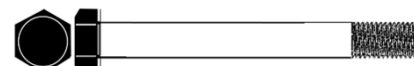

BEFORE YOU BEGIN, PLEASE VERIFY THAT THIS RACK WILL FIT YOUR SERVICE BODY.

#1- Side Channel kit 78010 will fit an 8ft. body mounted on an extended cab chassis. Side Channel kit 78000 will fit an 8ft. body mounted on a standard cab chassis. Side Channel kit 79010 will fit a 9ft. body mounted on an extended cab chassis, or an 11 ft. body mounted on a standard cab chassis. Side Channel kit 79000 will fit a 9ft. body mounted on a standard cab chassis.

#2- The "bulkhead" is the panel that is the front of the service body. Measure the distance from the top of the bulkhead to the top of the truck's cab. This distance should be in the range of 15" to 22".

#3- Standard mounting is on rear panel. Check to ensure that the rear panel of the service body is free of taillights or other obstructions (inside or out) in the area where the rear legs of the rack bolt to the body. Consult sketch below: Must be open unobstructed space at least 1.75" above tail light and below flip top box lid. Must be open unobstructed space of at least 1 1/4" to left or right of tail light. Distance from crown of roof plus 2 1/2" to top of mount bracket must be no greater than 24 1/2". Mount vertical leg of bracket (1 1/4") close as possible to vertical corner of rear body panel.

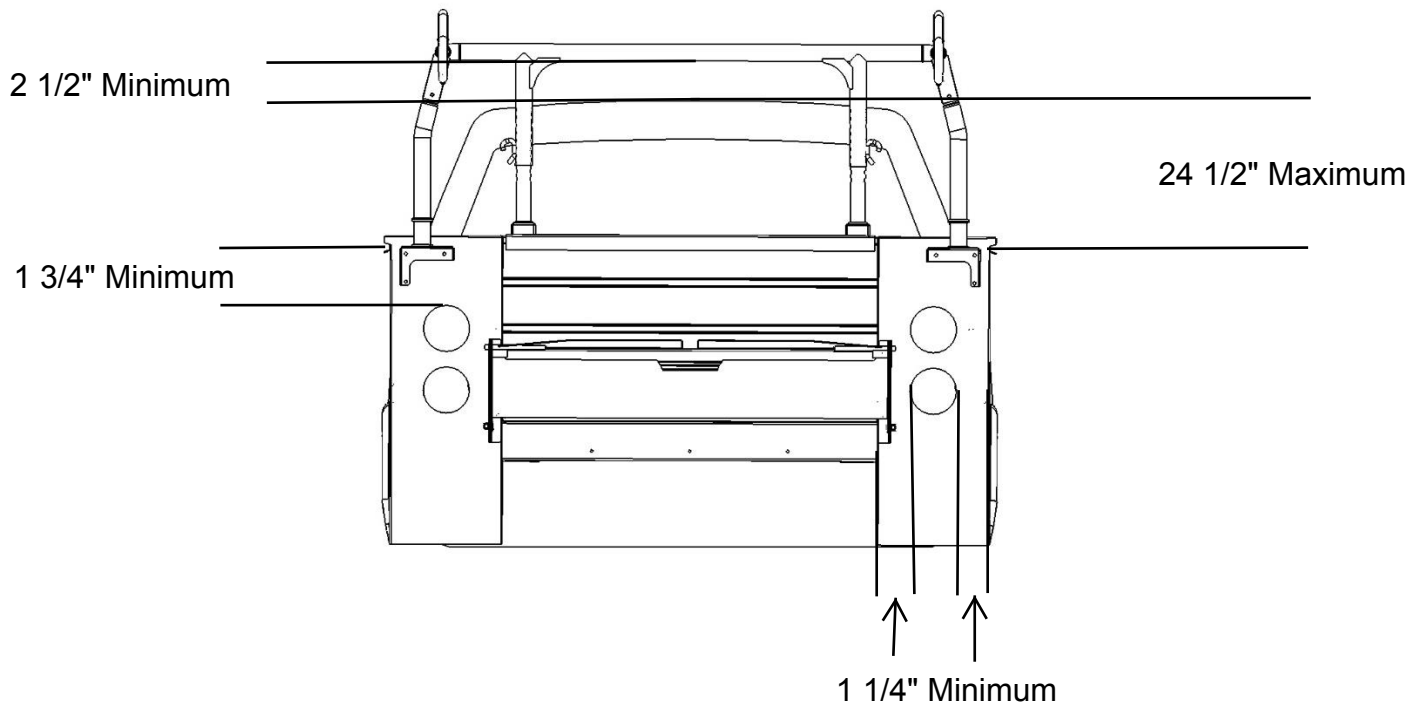

GOOP APPLICATION

Apply a healthy air tight bead of goop around **every** swaged joint as shown, to prevent moisture from leaking into and out of the joint. If this is not done properly, the inside surface of the tubes can rust and rusty water can leak out. Maintain this joint seal throughout the life of your rack.

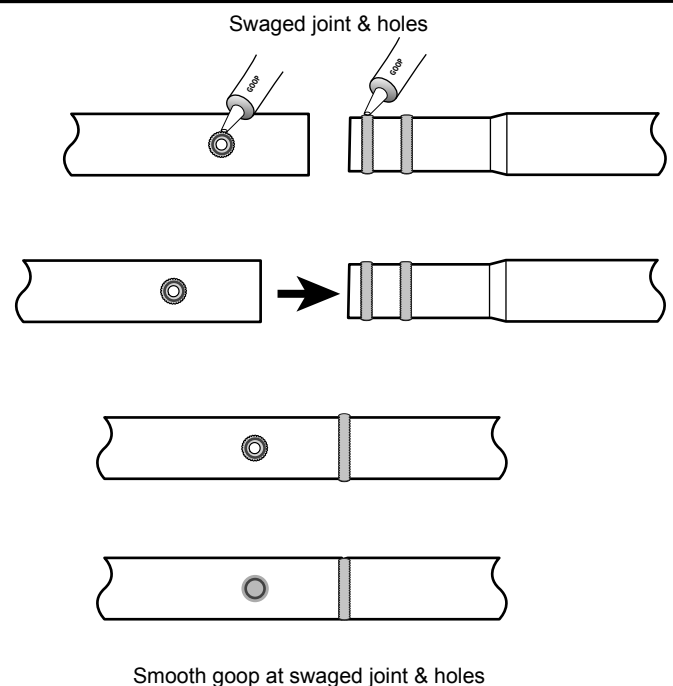

STEP 1

#1 = Cover entire swedge joints with GOOP and join FRONT and REAR side channels together. Be sure the connecting plates overlap and bolt together with bolts **Q**, washers **L** and lock nuts **M**.

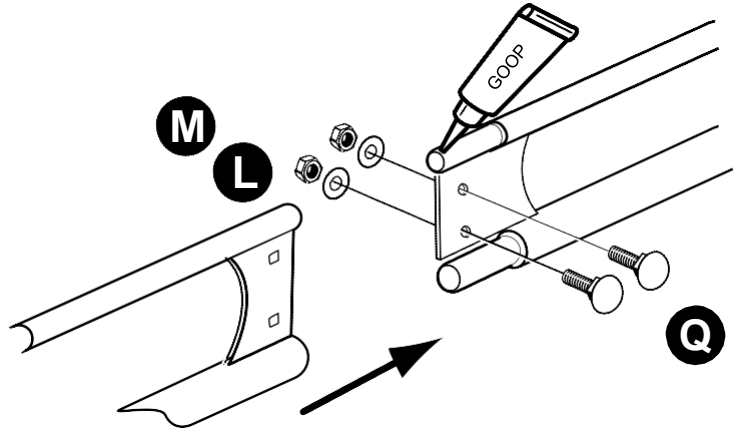

STEP 2

#1= Slide REAR BAR **D** on to REAR SIDE BEAMS **04** **06**

#2= Fully insert LOCK PINS **J** completely to the bend of the pin.

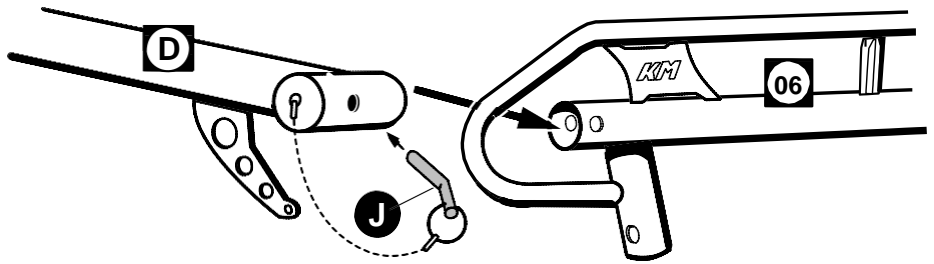

STEP 3

#1= Cover entire swedged joint surfaces with GOOP, Slide FRONT CROSS BAR **A**, into FRONT SIDE BEAMS **03**

#2= BOLT TOGETHER using **G**, **H** & **I**. The allen wrench is included in the package. REAR SIDE BEAMS

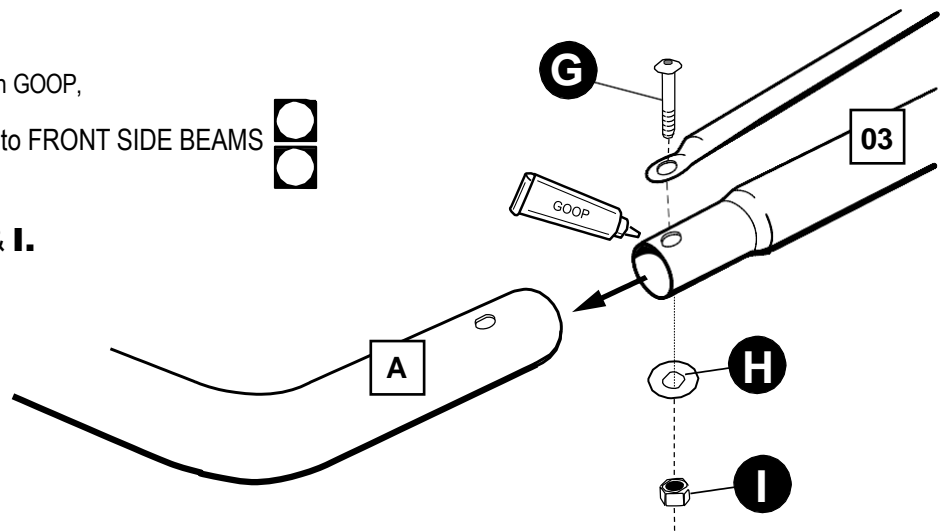

STEP 4

See recommended
"Support Tube"
installation on
following page.

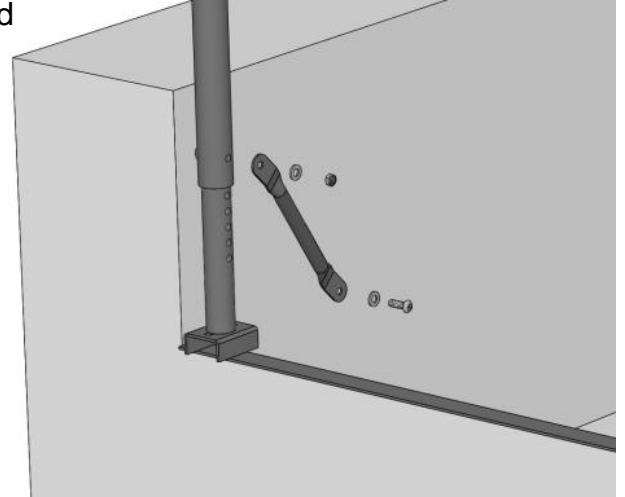

- #1=** Turn partially assembled rack upside down as shown. Cover entire swedged joint surfaces with GOOP, then insert the swedged end of each REAR leg, rope hooks facing outward, into the short tubes projecting from the bottom of the SIDE BEAMS.

- #2=** Bolt REAR LEGS and REAR BAR BRACE (as shown)

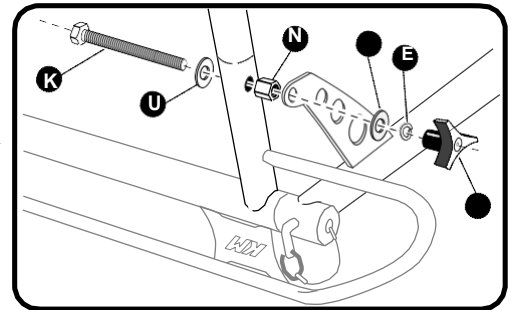

- #3=** After determining your service body length, attach FRONT CROSS BAR to appropriate "U Clips" with bolts **P**, flat washer **H** and jam nut **I**.

NOTE: 11 ft "U-Clip will be on the 79010 model only.

- #4=** Start bolt **P**, with lock washer **O**, flat washer **H**, into ends of 4th CROSS BAR, position onto rack then with an open end 3/4" wrench, snug bolts on each side of the rack.

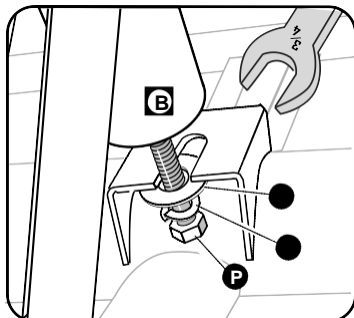
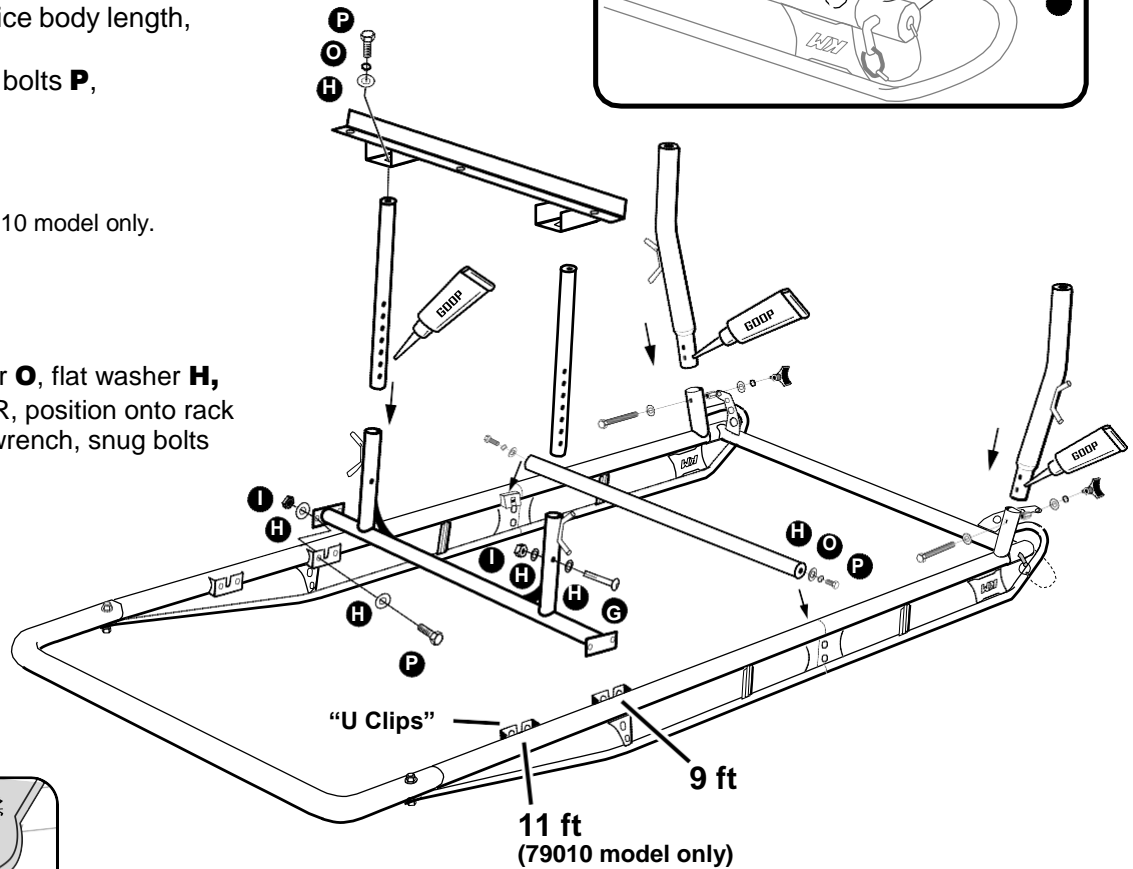



Recommended support installation.

In the front of the service body, Place corner support (70020-10-010) into corner as shown. The bracket should be touching 3 panels of the service body. Mark the 3 holes parallel with the cab and the two holes on the side box. Drill with 5/16" drill.

Be sure not to drill into anything on the backside of the marked holes

Bolt corner support to service body using 5/16" hardware. For each drilled hole, use one 5/16" x 1" Hex Head bolt, two 5/16" flat washers and a 5/16" Nyloc nut. Start with the two holes into the side box as shown.

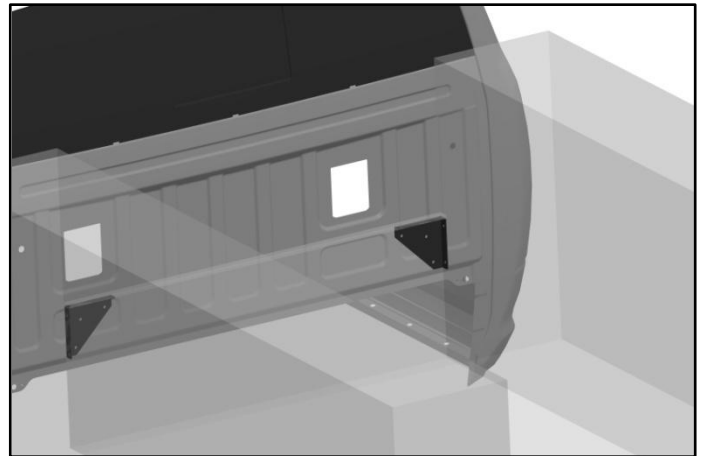

Passenger Side

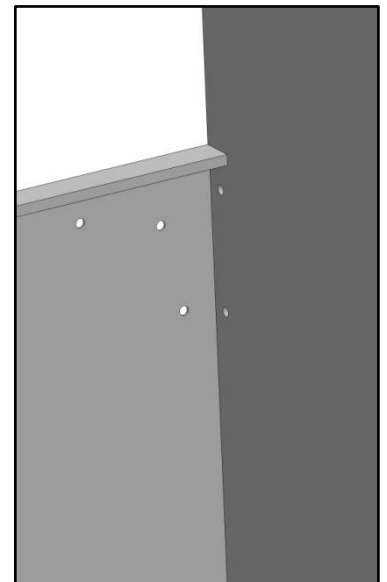
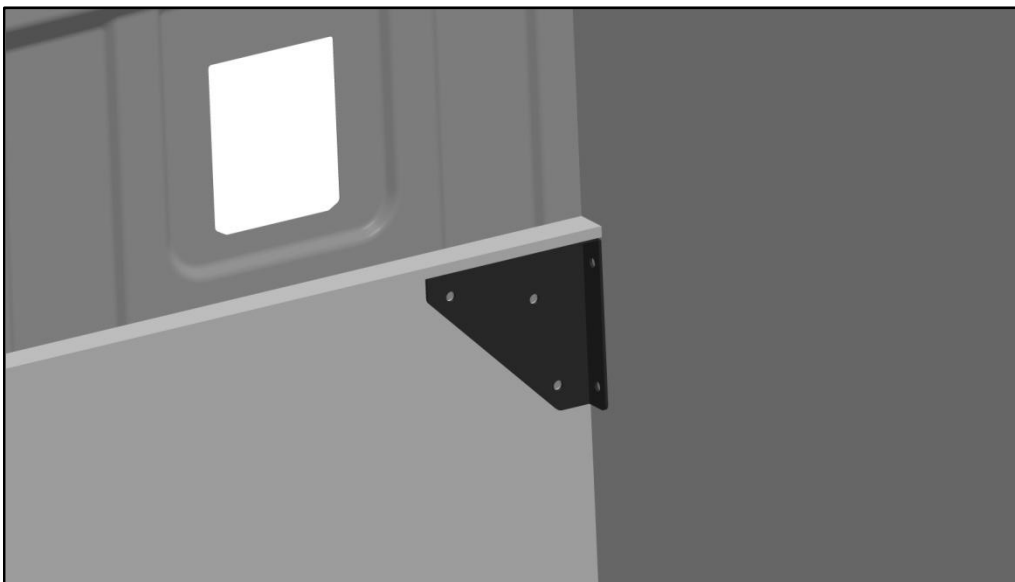

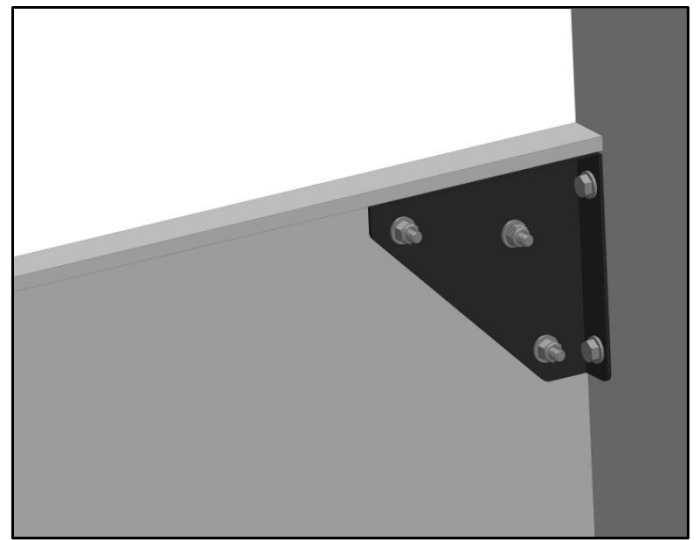
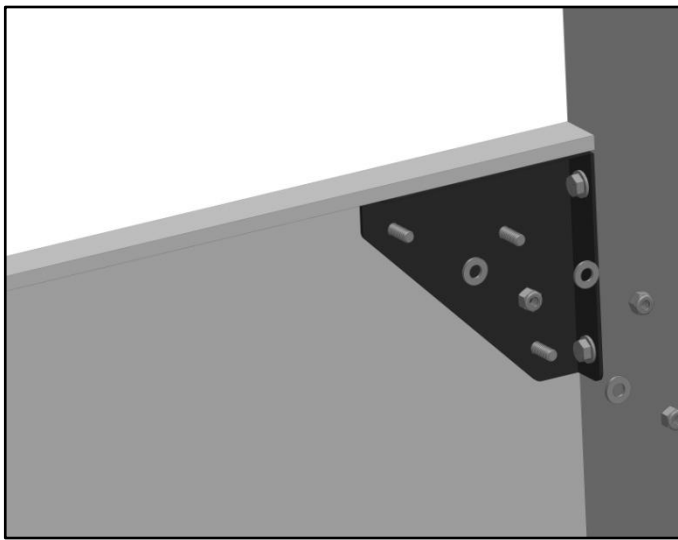
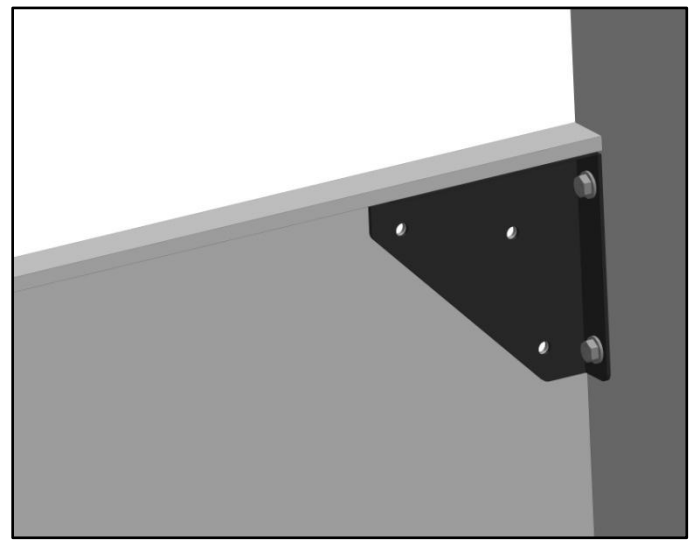
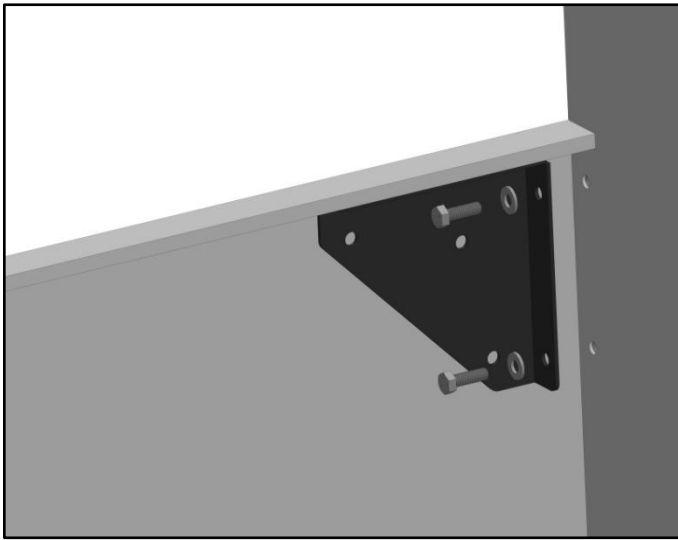

We recommend installing support tube (11-00757) to the front legs directly behind the cab of the vehicle. If front legs already bolted to top assembly, replace 1/2" x 2.5" Button head bolt with a 1/2" x 3.25" bolt. Along with bolt, use two 1/2" flat washers and a 1/2" Nyloc Nut.

****In some cases, support tube will go on the other side of front leg than what is shown****

DO NOT TIGHTEN

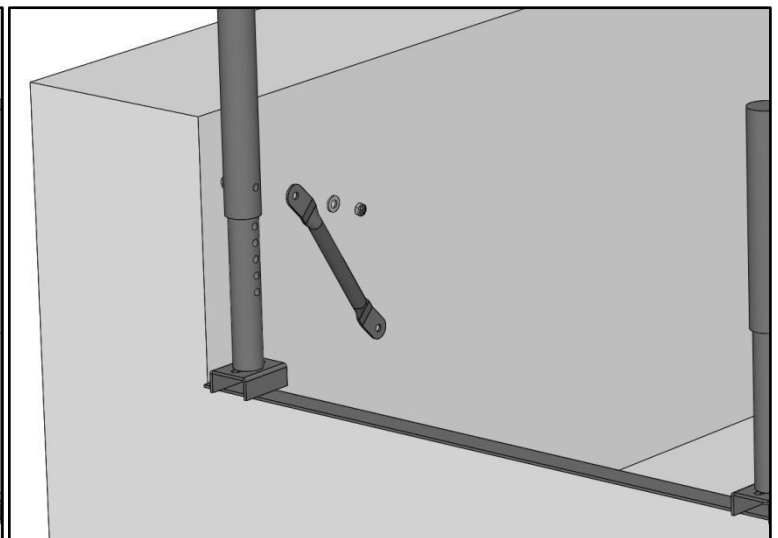
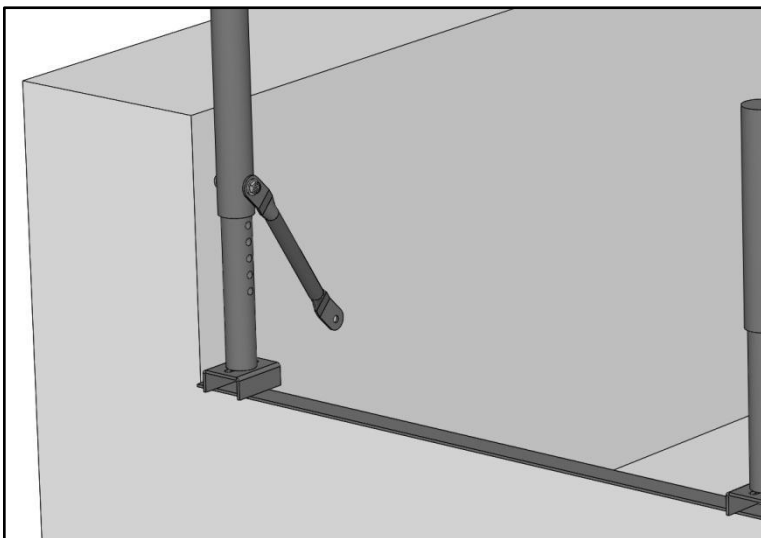

Approximately align your tube at a 45 degree angle. Mark through the bottom hole of the support tube into the side of your service body.

Be sure you can access the back side of where the hole was marked. Make sure nothing important is behind marked hole.

Drill a 3/8" hole through the service body.

Bolt bottom of support tube to service body using a 3/8" x 1" Button Head, two 3/8" flat washers and a 3/8" Nyloc Nut.

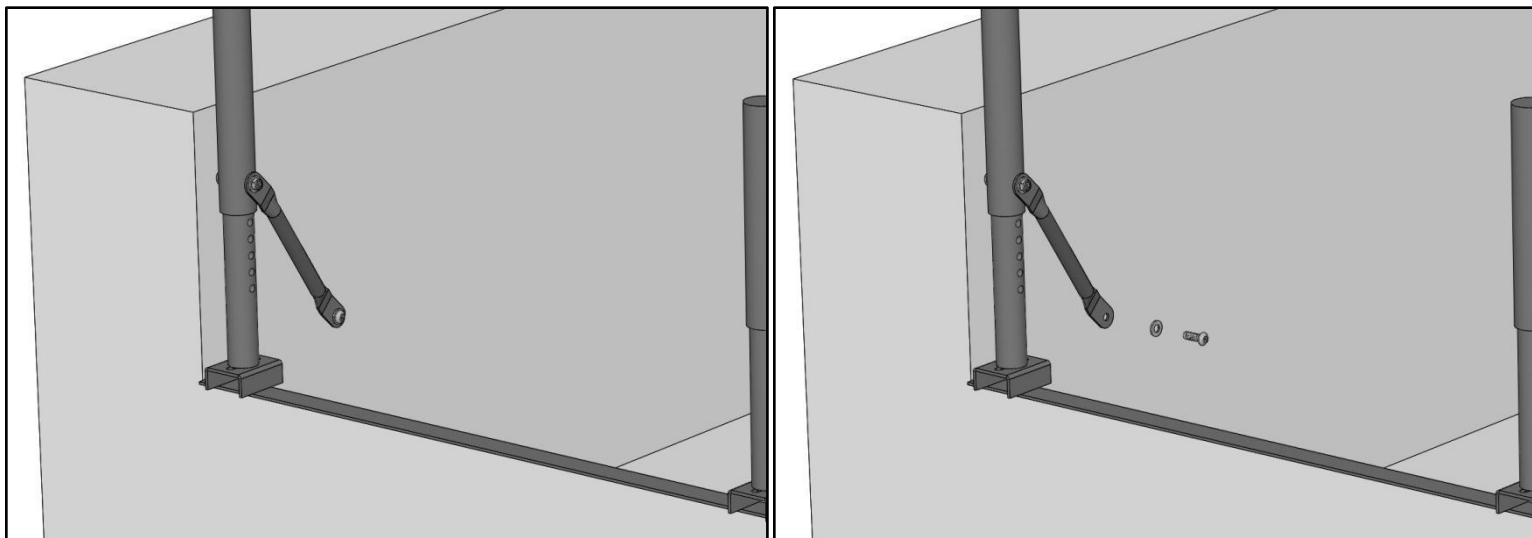

Repeat on both sides.

Tighten all bolts.

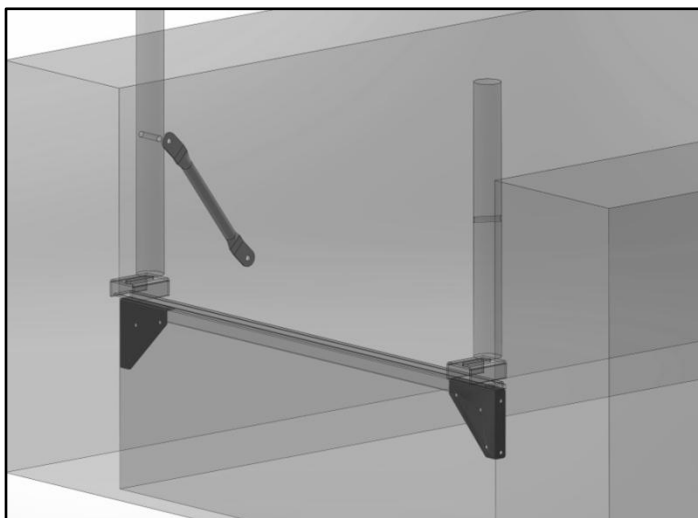

STEP 6

#1= Set rack on the service body, with the "bulkhead angle iron mounting bracket" centered between the boxes and pushed forward against the bulkhead. Bring the rack approximately level, and support the rear with clamps, blocks, or forklift. Bolt the bulkhead mounting bracket to bulkhead using bolts **V**, flat washers **U** and lock nuts **R**. Push the rack forward in the mounting bracket slots so that the rear leg mount plates are firmly against the rear of the service body boxes and position the mounts so that the rack is level and centered. Before drilling holes in the service body, check to ensure that the CROSS BAR is about 3" higher than the truck cab. Drill holes with a 3/8" drill bit through the back of the boxes and attach the rear mounting plates with button head bolts **V**, flat washers **U** and lock nuts **R**. Bolt the legs (loosely) to mounting plates with bolts **P**, lock washers **O** and flat washers **H**.

#2= Tighten down **ALL** bolts except **P** bolts.

#3= The lock pins (**J**) securing the removable rear cross bar (**D**) will not slide in and out easily unless the holes are aligned. Move each rear leg left or right in the slot to ensure proper alignment. Tighten bolts **P**.

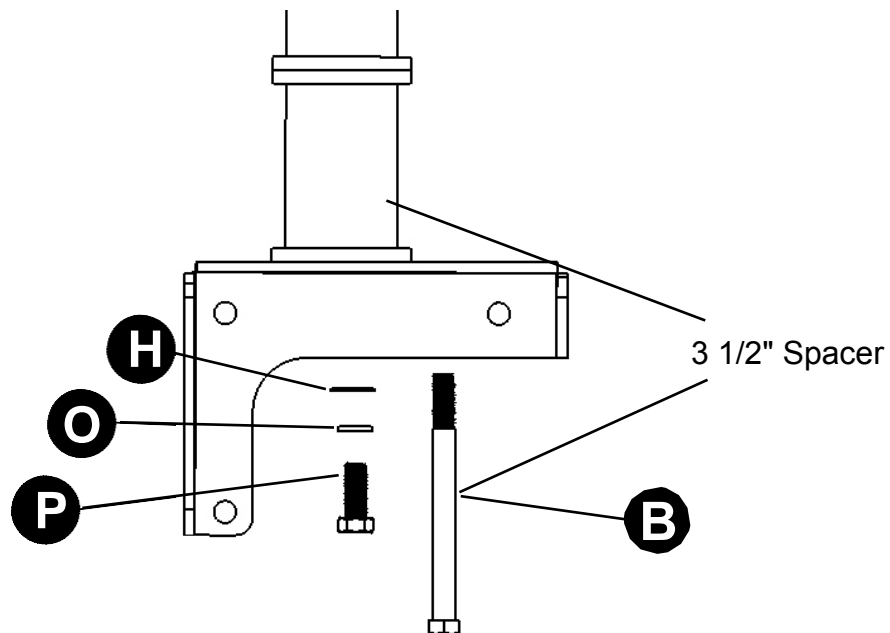

Tighten down all nuts & bolts and **THAT'S IT!** You are now ready to use your rack.

DON'T OVERLOAD YOUR VEHICLE!

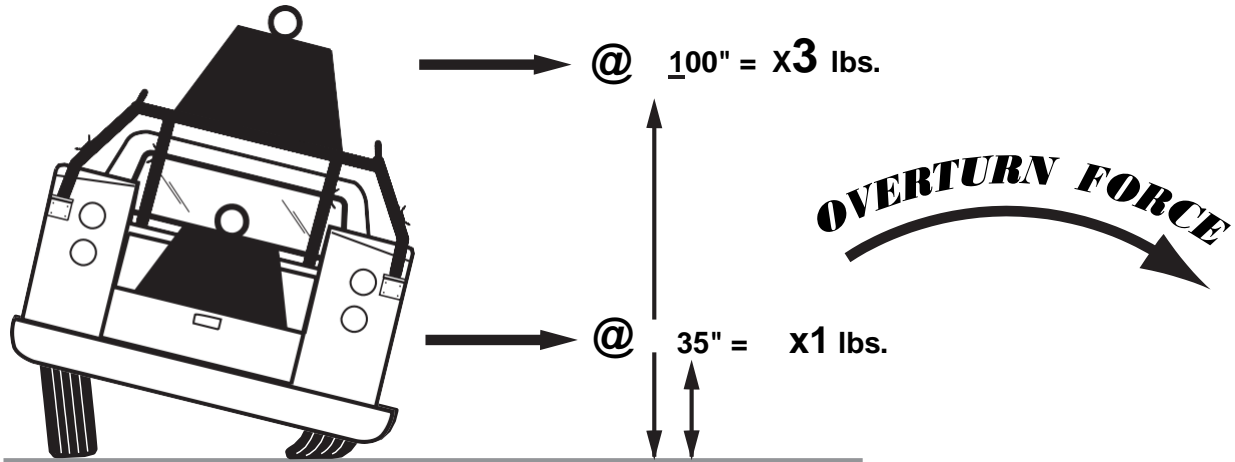

WEIGHT CARRIED ABOVE THE FLOOR OF THE TRUCK BED (E.G. ON AN OVERHEAD TRUCK RACK) WILL SIGNIFICANTLY INCREASE THE VEHICLE'S TENDENCY TO OVERTURN. ALWAYS KEEP HEAVY LOADS EVENLY DISTRIBUTED AND AS LOW AS POSSIBLE. IT IS IMPORTANT TO NOTE THAT THE KARGO MASTER RACK LOAD BEARING CAPACITY OF 1700 LBS. MAY BE GREATER THAN YOUR TRUCK'S GAWR OR GVWR CAPACITY, AND IS PROBABLY GREATER THAN THE WEIGHT THAT CAN BE SAFELY CARRIED OVERHEAD.

For *TECHNICAL SUPPORT* Call: **1.800.343.7486**
HOURS: Monday- Friday 8:00 A.M. to 4:30 P.M. (PACIFIC)