

40933 Parts List

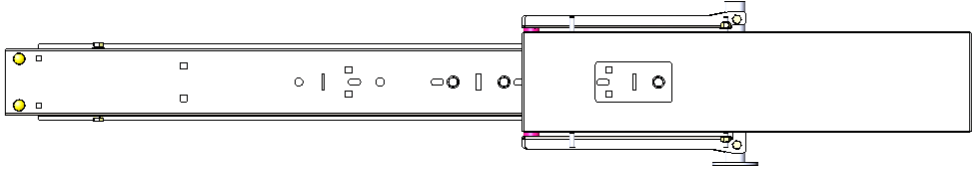

Front Bow Assy. (1)

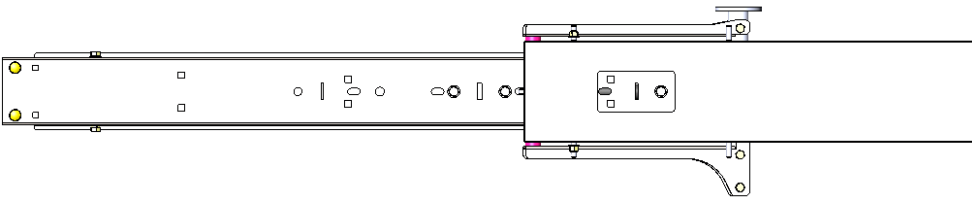

Rear Bow Assy. (1)



Rail Mount Foot (4)



Latch (1)

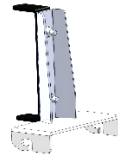

Ladder Hook (2)



Ladder Stop (2)



Torque Tube (1)



Ladder Pan Stiffener (1)



Mount Rail (2)









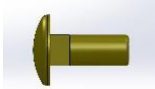

Handle Assy. (1)

40933 Hardware List









Tools Needed

8' Tape Measure	1/2" End Wrench
1/2" Socket	9/16" End Wrench
9/16" Socket	Hammer
7/16 Socket	

Hardware Pack

(a) Qty 6 - 5/16"-18 x 3/4" Carriage Bolt	
(b) Qty 26 - 5/16" Flat Washer	
(c) Qty 8 - 5/16" Lock Washer	
(d) Qty 14 - 5/16"-18 Nyloc Nut	
(e) Qty 4 - 5/16"-18 x 5/8" Hex Bolt	
(f) Qty 4 - Round Rubber pad	
(g) Qty 4 - Fender Washer - 24mm OD x 2mm TK	
(h) Qty 4 - M8 Nyloc nut	

Hardware Pack Cont'

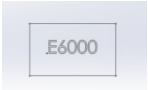
(i) Qty 4 - 5/16"-18 x 1" Hex Bolt	
(j) Qty 8 - 3/8"-16 x 3/4" Hex Bolt	
(k) Qty 8 - 3/8" Flat Washer	
(l) Qty 8 - 3/8" Lock Washer	
(m) Qty 6 - 1/4"-20 x 7/8" Fully Threaded Hex Bolt	
(n) Qty 12 - 1/4" Washer	
(o) Qty 6 - 1/4"-20 Nyloc Nut	
(p) Qty 4 - M8 x 25mm Hex Bolt	
(q) Qty 2 - M8 x 20mm Counter Sink Bolt	
(r) Qty 1 - Joint Sealant	

For TECHNICAL SUPPORT Call: 800-343-7486 Monday - Friday 7:00 A.M. to 4:00 P.M (PST)

Step 1

Mount rail to roof using M8x25 Bolts with flat and lock washers (on 2014 Transit Connect use nyloc nut with fender washer and rubber washer-Do not use lock washer). Mount rail so that the end of the rail is 1-2" approximately (usually the 2nd or 3rd hole-Use countersunk hole for 2013 and older Transit Connect) from where the rear door opening is.

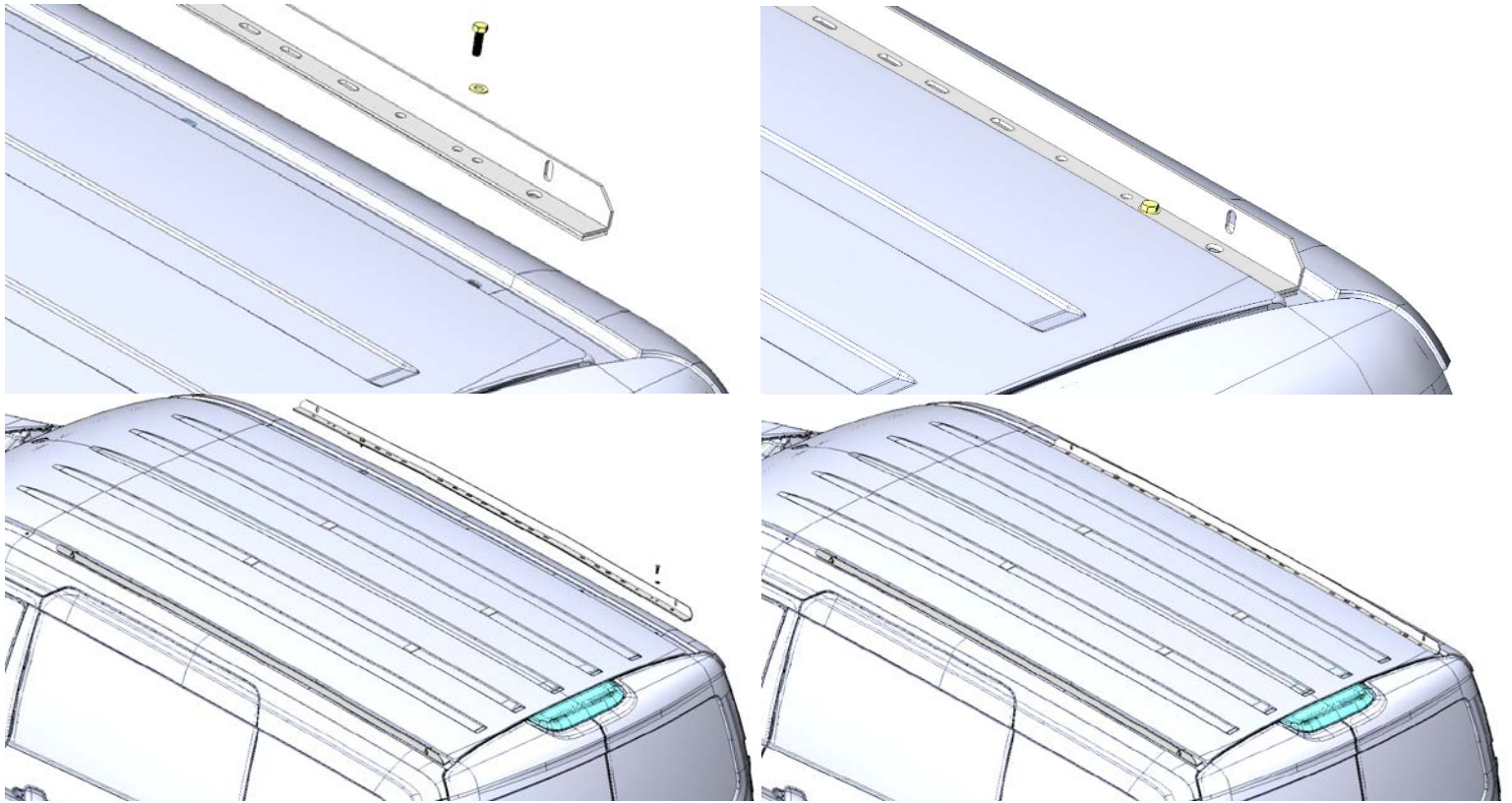

Step 2

Measure width the rail and bolt feet to bows at that approximate location as shown, DO NOT TIGHTEN at this point.

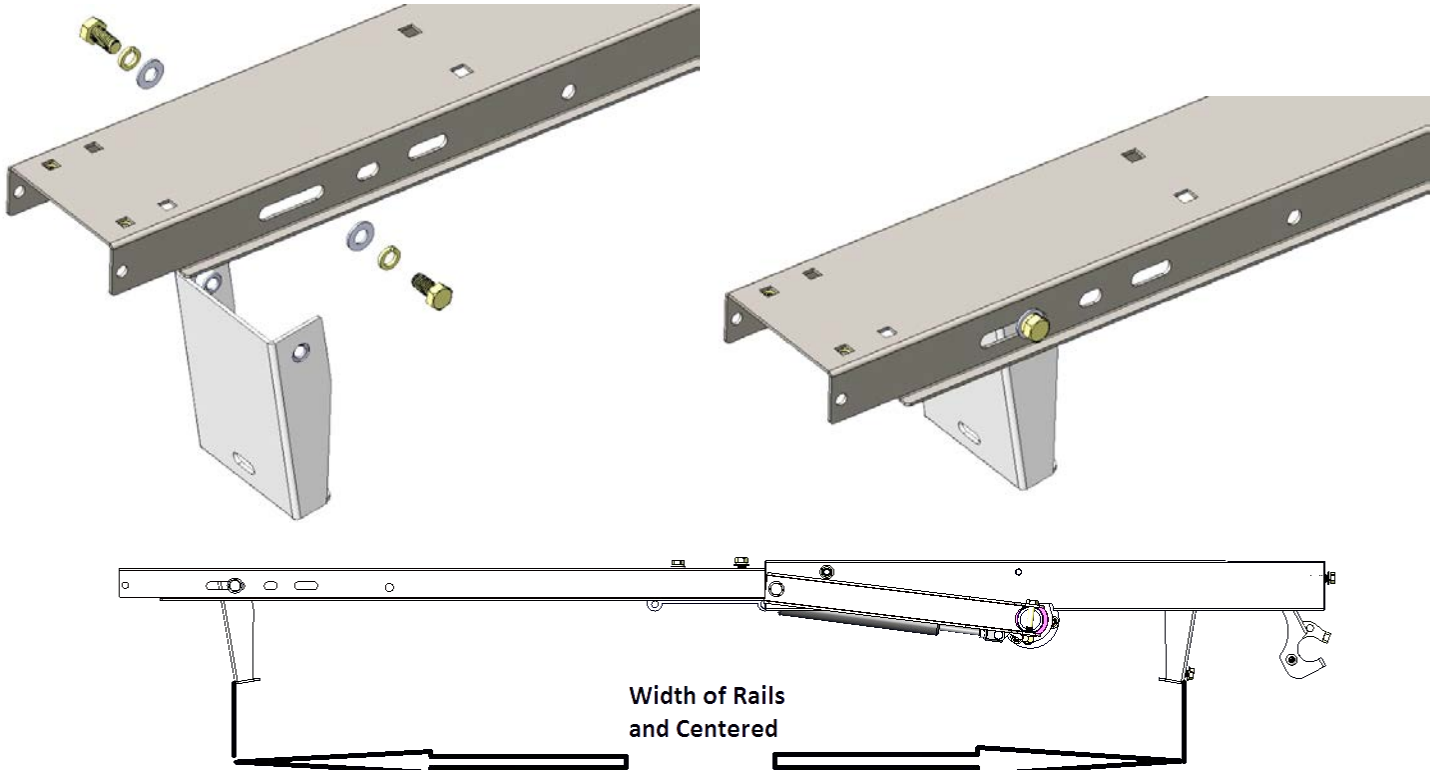

Step 3

Bolt "Latch" as shown using 5/16"x3/4" carriage bolts with nyloc nuts and flat washers.

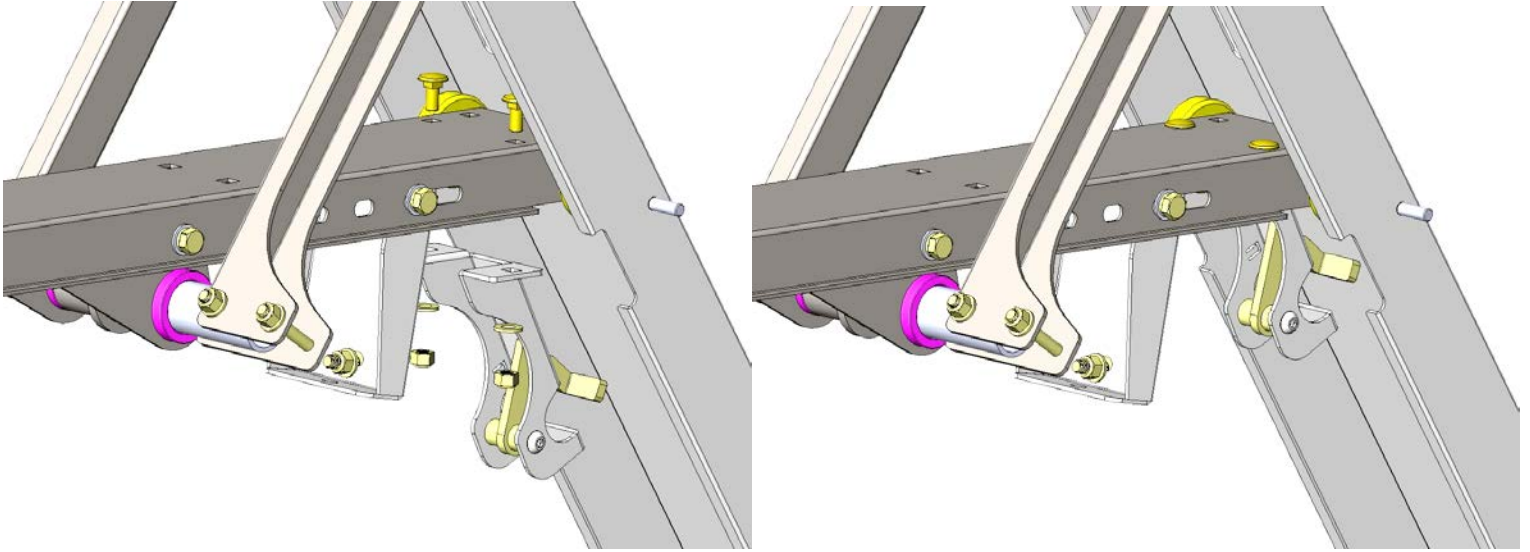

Step 4

Next bolt the Angle bracket on the driver side of the bows using 5/16"x3/4" carriage bolts with nyloc nuts and flat washer as shown.

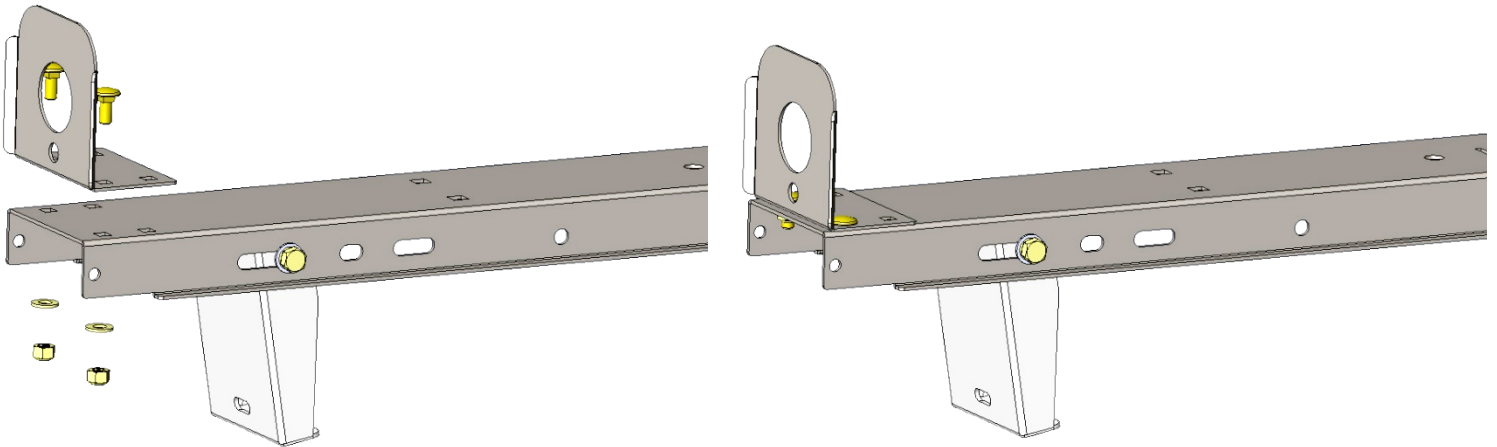

Step 5

Place "Rear Bow Assy." as shown and bolt to rails using 5/16"x1" bolts with nyloc nuts and flat washers, DO NOT TIGHTEN at this time.

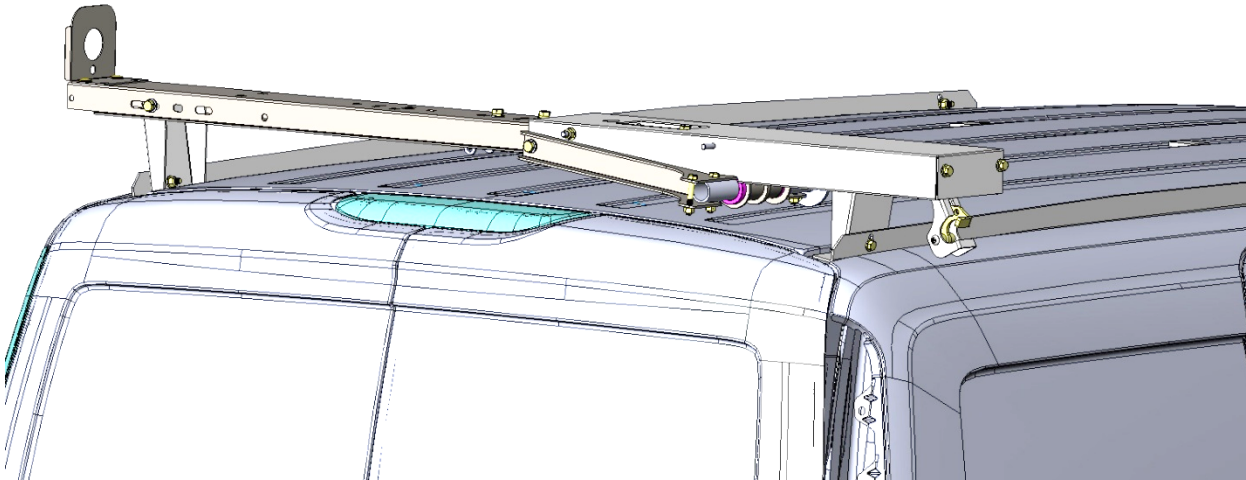
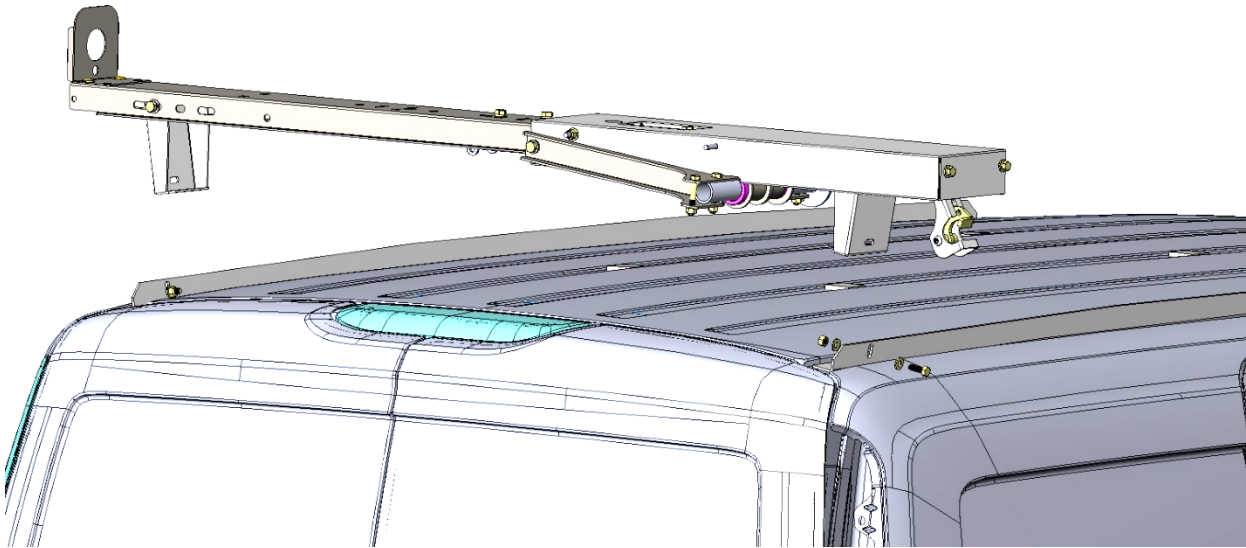

Step 6

Place "Front Bow Assy." as shown and bolt to rails using 5/16"x1" bolts with nyloc nuts and flat washers, DO NOT TIGHTEN at this time.

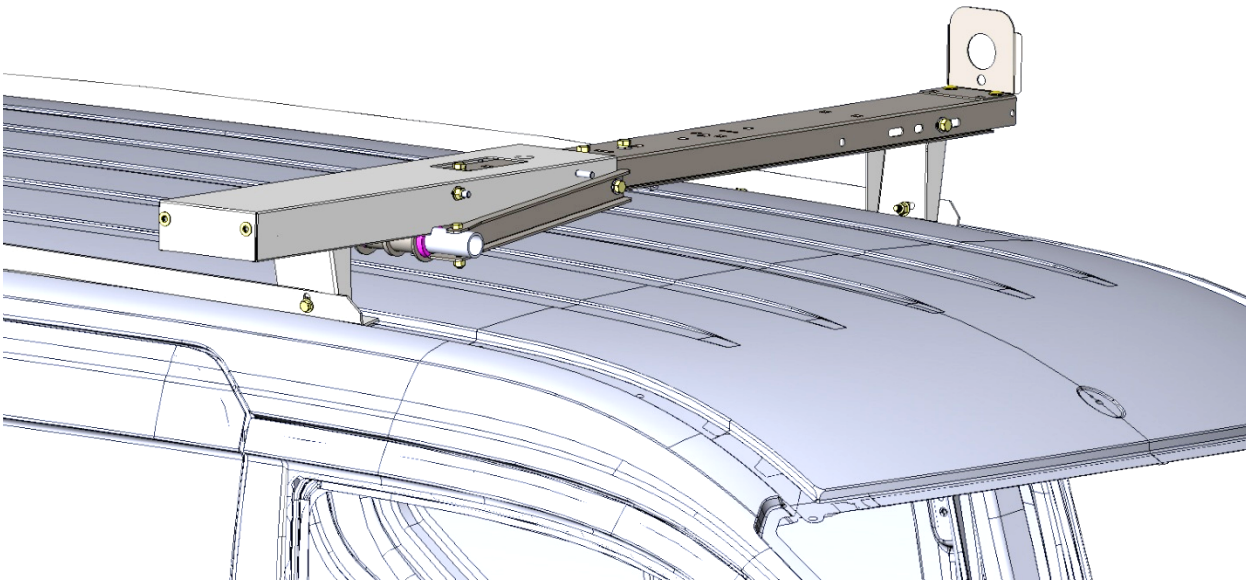
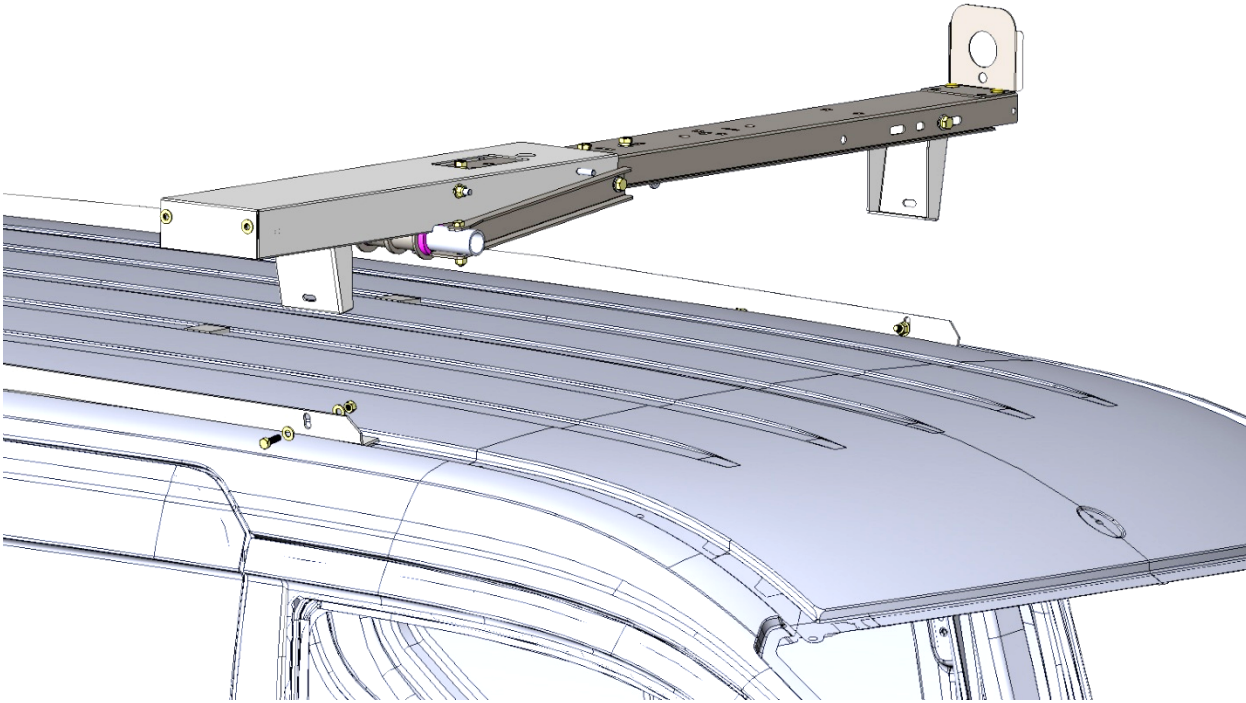

Step 7

Bolt the "Torque Tube" using $\frac{1}{4}$ "x $\frac{7}{8}$ " bolt with nyloc nut and flat washers. This sets the distance between the front and rear assembly (71.5" center to center), be sure both sides measure the same to ensure proper operation.

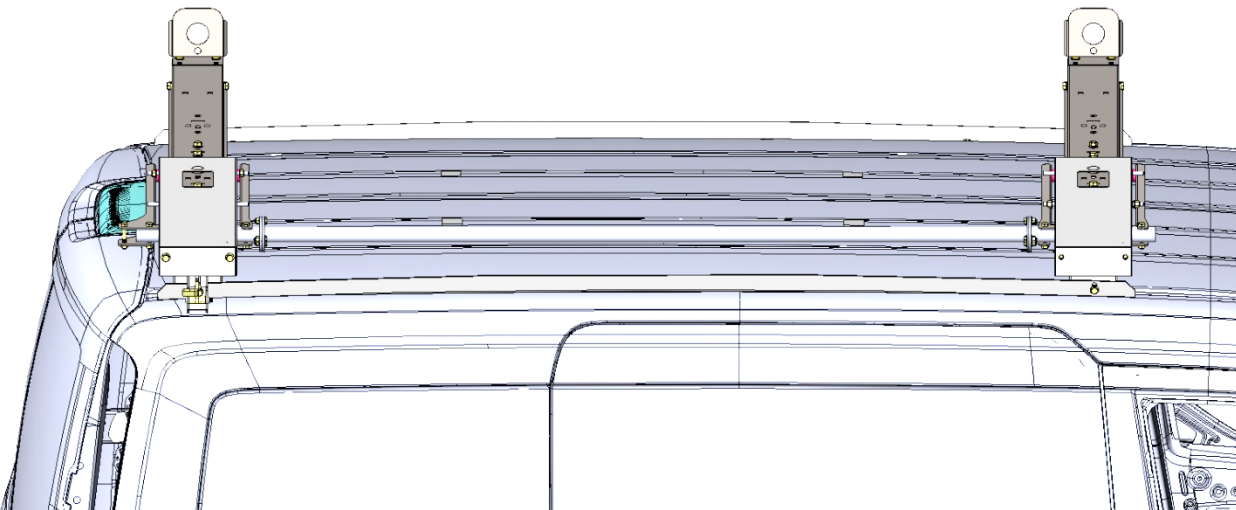
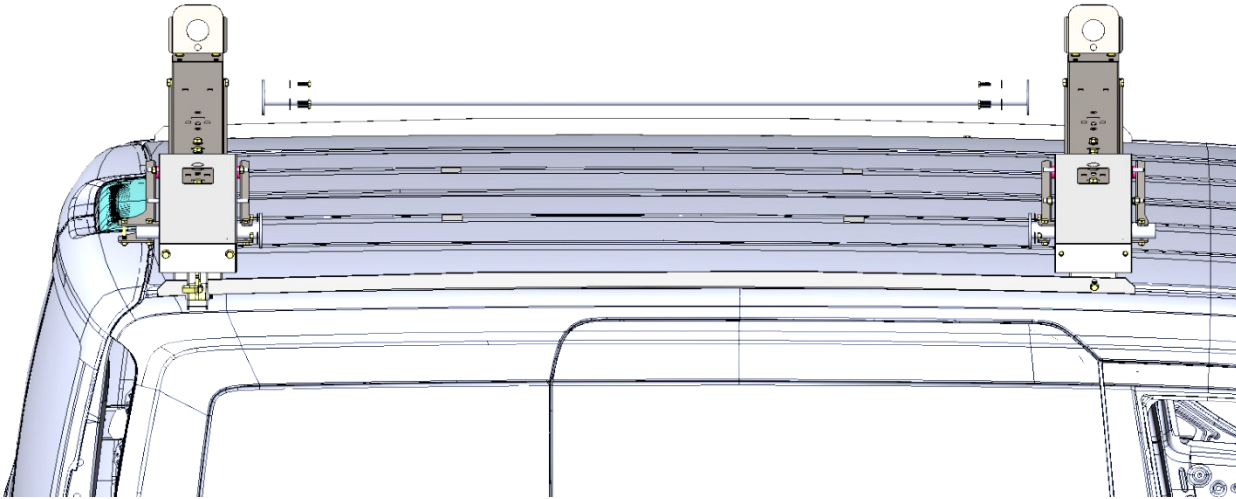
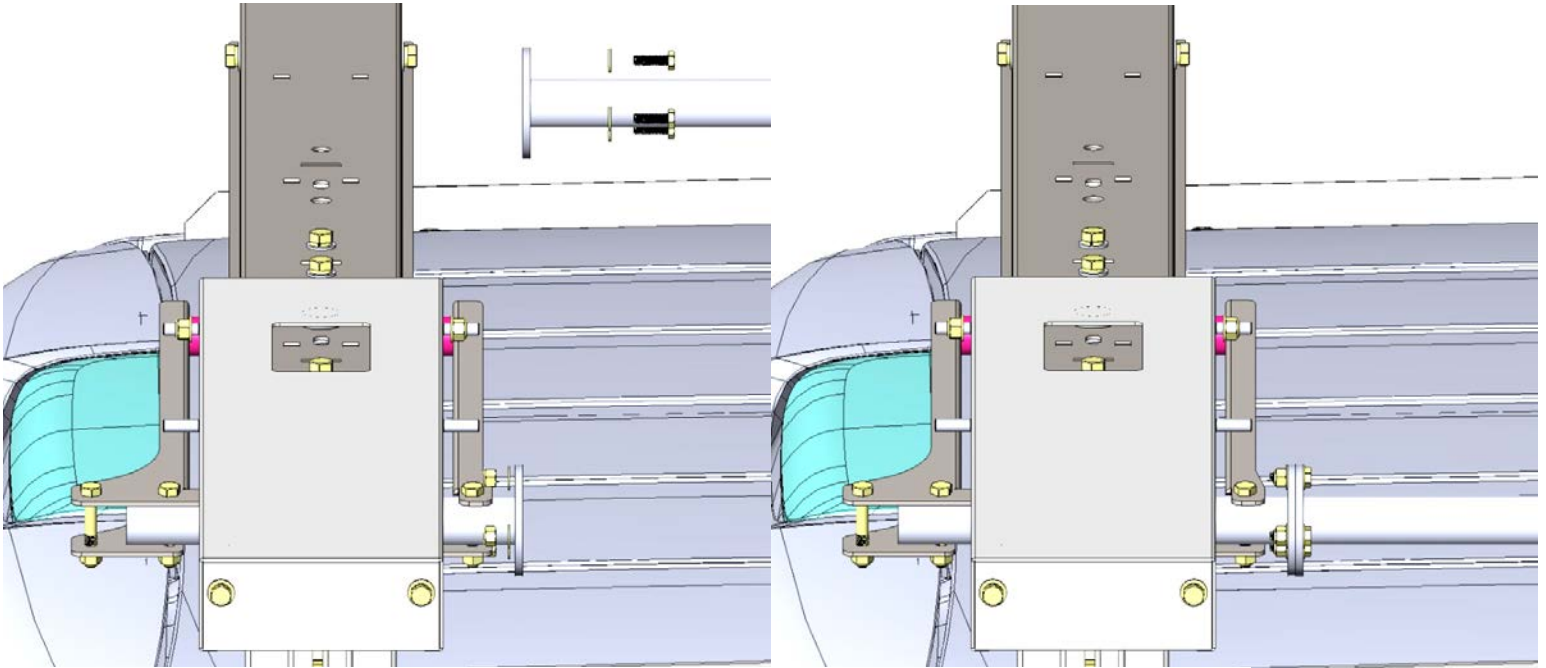

Step 8

Next bolt the "Handle Assy." Using 5/16"x2" bolts with a nyloc nut and flat washers as shown. BE SURE HANDLE WILL CLEAR THE REAR DOORS during operation. If it doesn't clear then the rails need to be mounted back farther on the van.

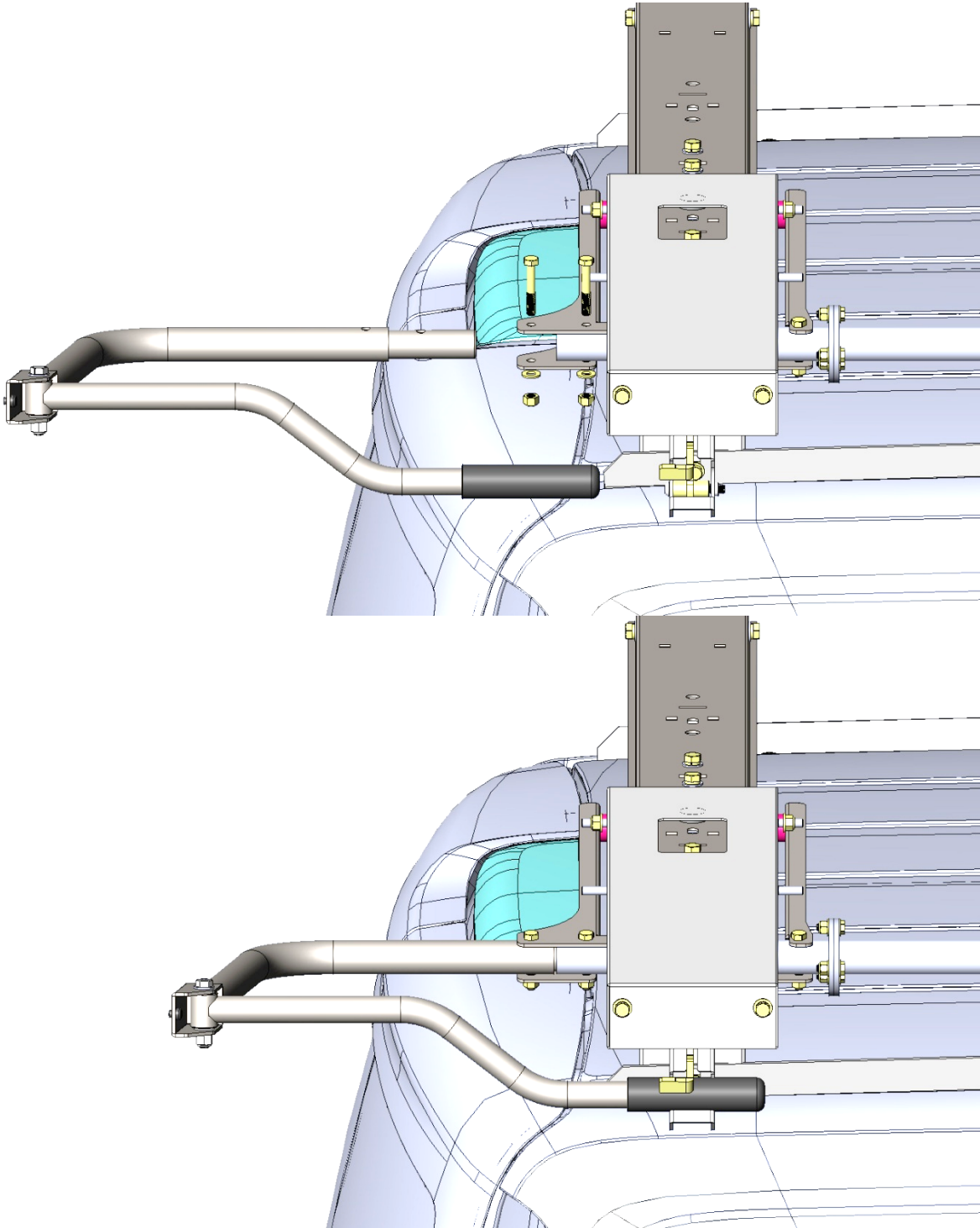

Step 9

Next attach the “Ladder Pan Stiffener” using 5/16”x5/8” bolt with lock washers and flat washers as shown. With that completed you can now go back and tighten the feet to the rails and then the feet to the front and rear bow assemblies, double check the center to center dimension before tightening (71.5”).

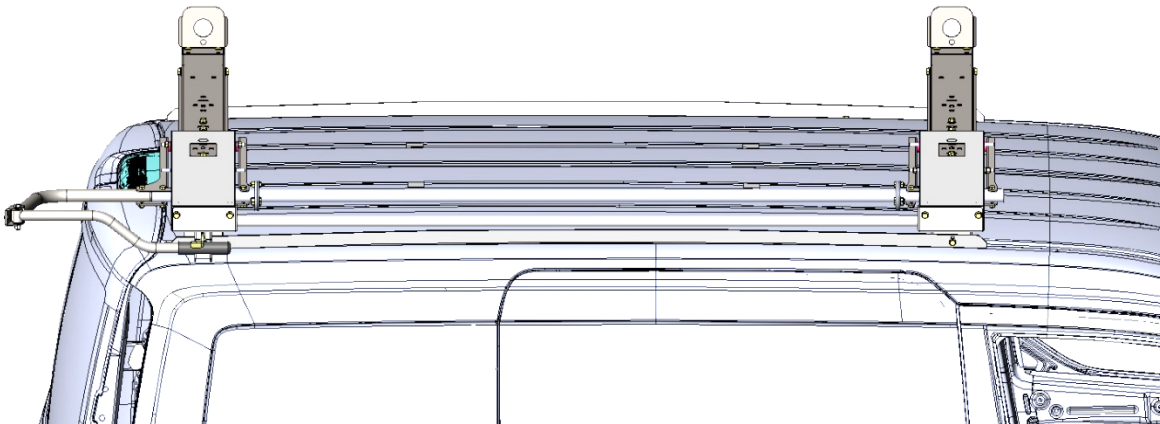
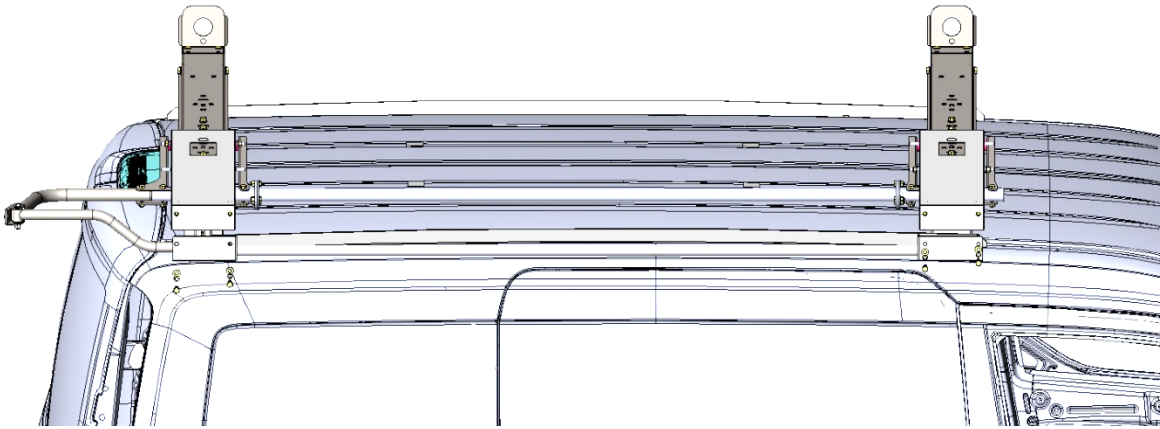
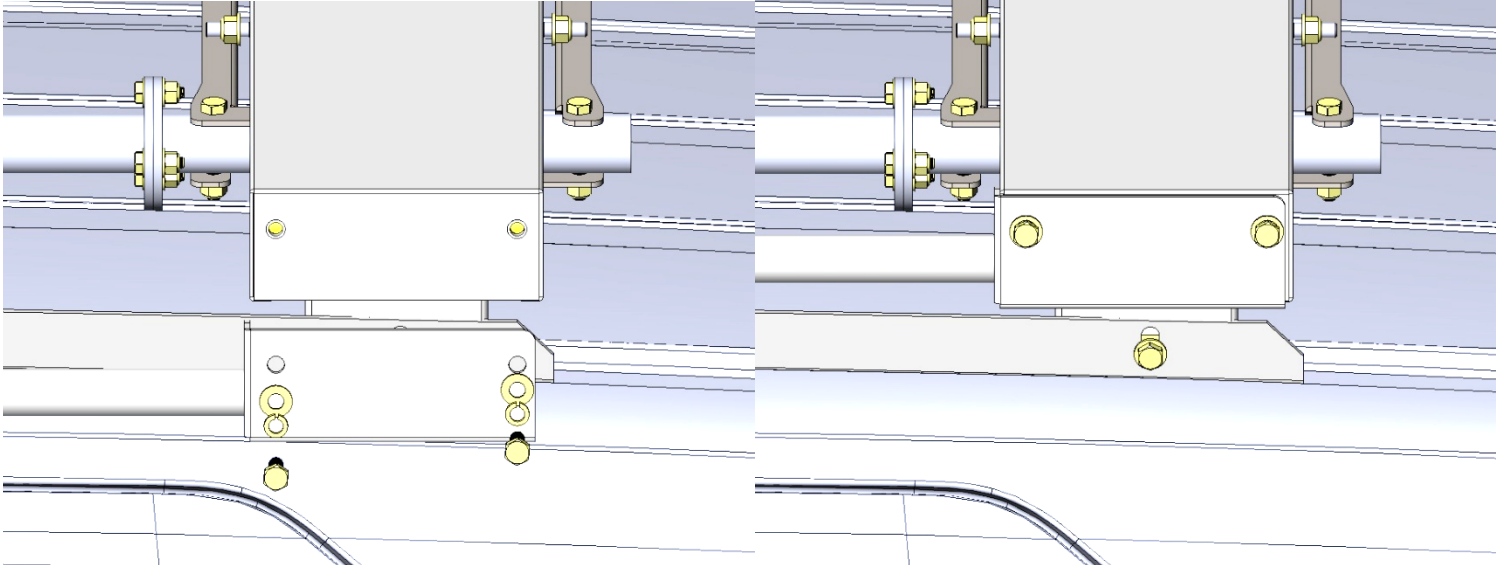

Step 10

Next attach the “Ladder Hooks” and “Ladder Stops”. The first 4 pictures show the front hooks, the next 4 show the rear hook set in the “step ladder” location. If you are using an extension ladder use the same location as the front bow.

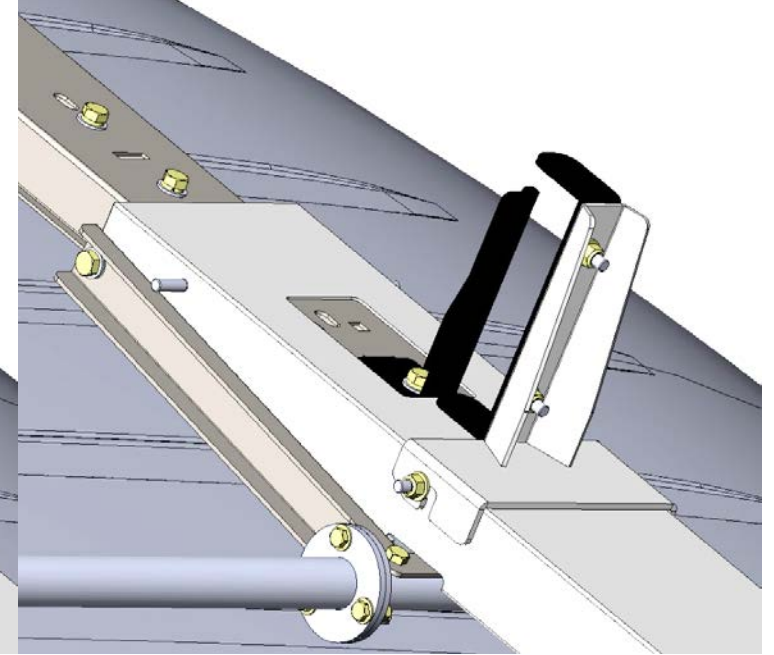
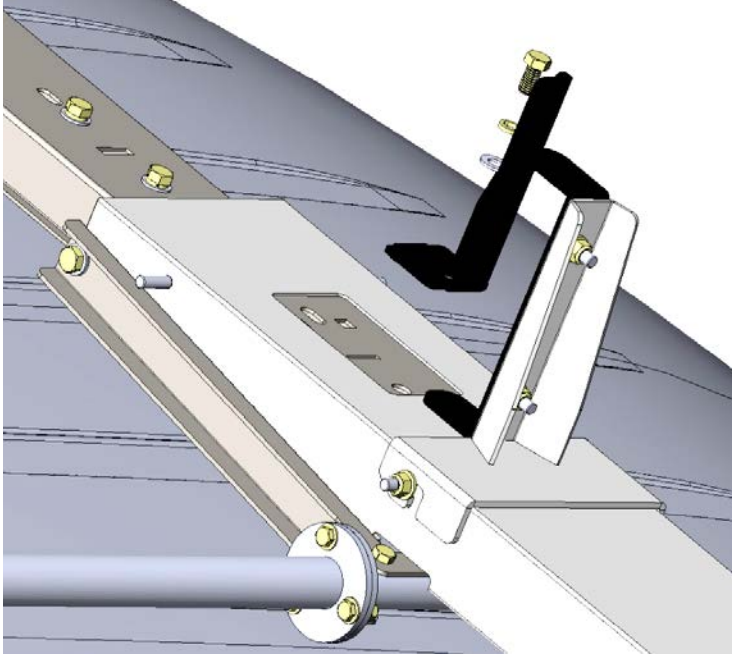
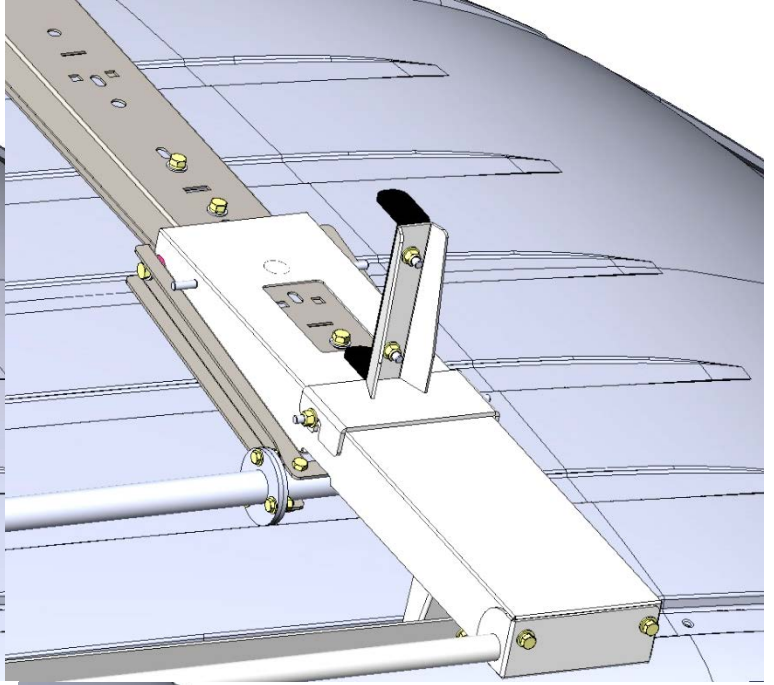
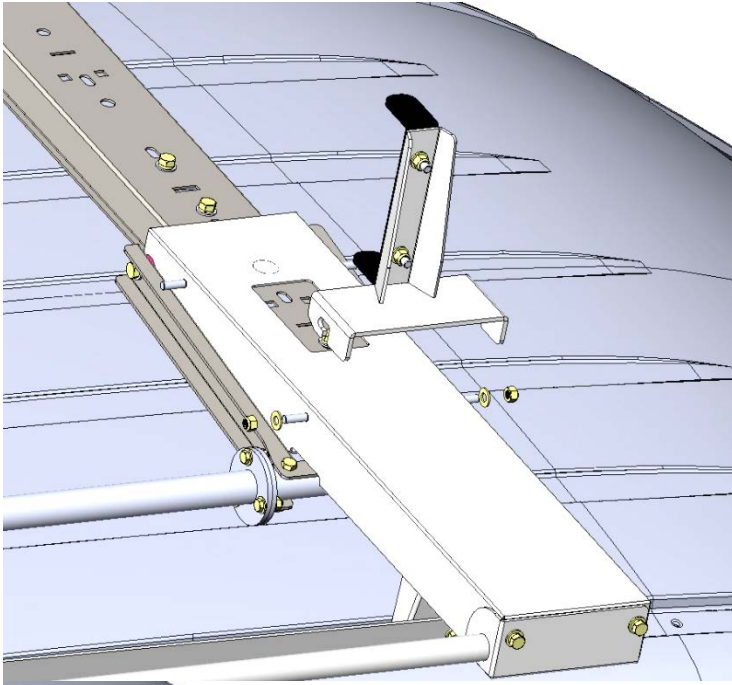

Rear bow location for step ladder.

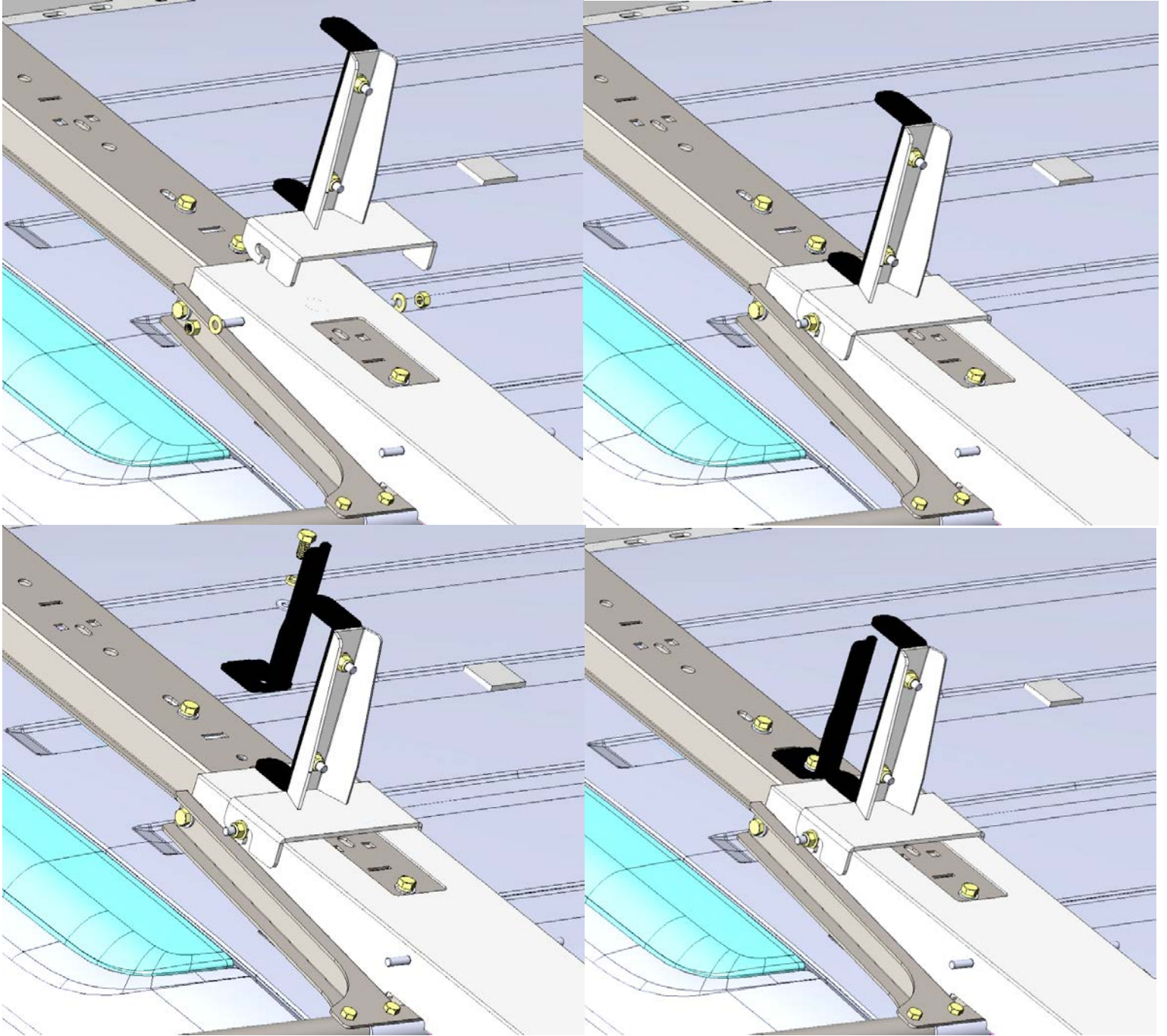

Installation complete for "step ladder".

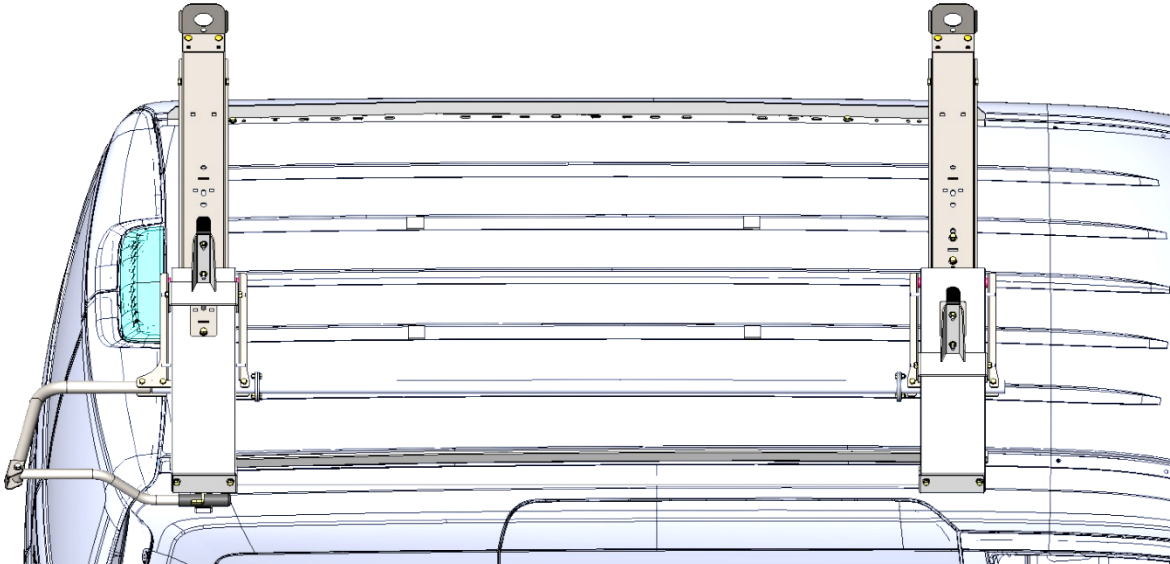

Installation complete for "extension ladder".

